

# YCC SUBMERSIBLE MOTOR

180 THRU 360L FRAMES

## INSTALLATION, OPERATION AND MAINTENANCE MANUAL

*Note: FOR 140 FRAME MOTORS PLEASE REFER TO INSTRUCTION 9900-140*

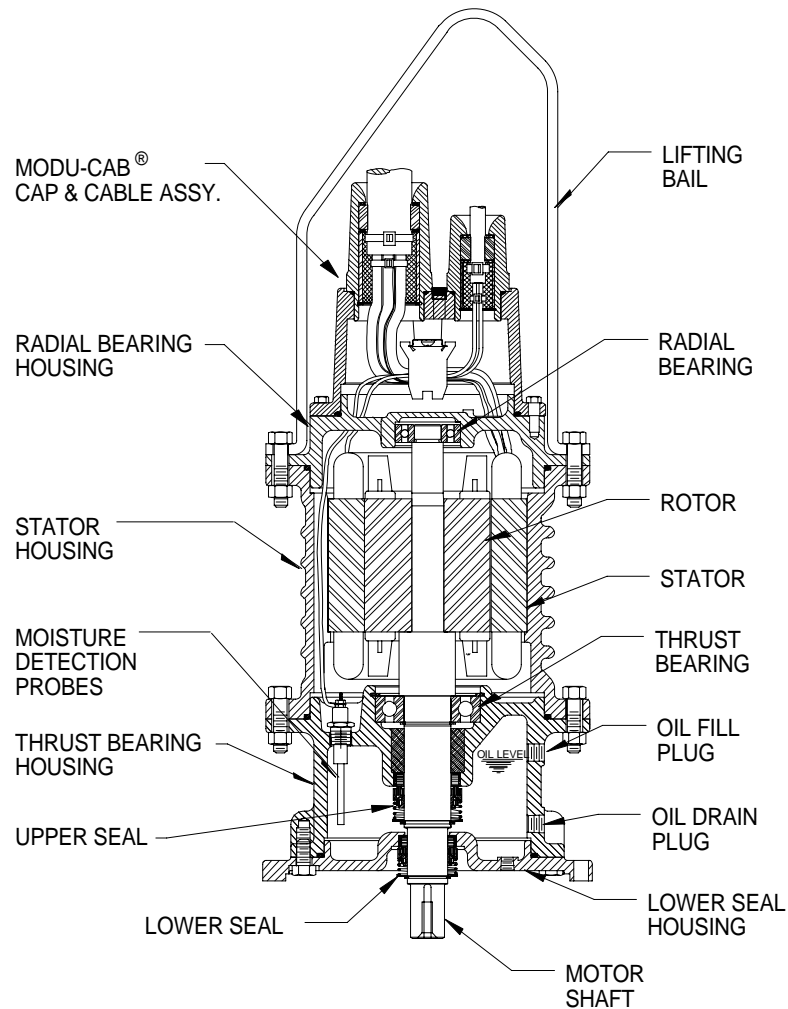

### TYPICAL MOTOR DETAIL



**3905 ENTERPRISE COURT  
AURORA, IL 60504 USA**

[www.yccpump.com](http://www.yccpump.com)

# Table of Contents

	Page
Acceptance of Shipment, Caution Statements.....	3
General Notes.....	4
Factory Mutual (FM) Approved Motors.....	4
Long Term Storage Instructions.....	5
Installation Notes.....	5
Start Up.....	6
Maintenance.....	6
Thermal Protection System .....	7
Table 1 – Maximum Current Capacity of Motor Thermostats.....	7
Moisture Detection System .....	7
Disassembly Instructions	
For Electrical Repairs.....	9
For Mechanical Repairs .....	9
Re-assembly Instructions .....	11
Table 2 - Recommended Oil Quantities for Motor Frames.....	13
Table 3 - Recommended Oil Types .....	13
Maintenance Data for Mechanical Seals.....	13
Figure 1 – Typical Wiring Diagram – Thermal Protectors.....	14
Figure 2 – Typical Wiring Diagram – Moisture Detection .....	14
Table 4 – Typical Power and Control Lead Color Coding.....	14
Figure 3 – Seal Cap and Motor Wiring Diagram (Typical All Frames) 112394.....	15
Figure 4 – Seal Cap and Motor Wiring Diagram (Dual Power Cables) 112395.....	16
Figure 5 – Motor Cross Section Drawing (180, 210 and 250 frames) 109568.....	17
Figure 6 – Motor Cross Section Drawing (320 and 360 frames) 110497.....	18
Figure 7 – MODU-CAB® Cap & Cable System – Cross Section Drawing.....	20
Figure 8 – Parts List for Figures 5, 6 and 7 (Typical All Sizes) 110497.....	20
**MECHANICAL SEAL ADDENDUM.....	21
Typical Motor Data.....	21~25
MODU-CAB® Replacement Parts & Rebuild Kits.....	26~27
MODU-CAB® Cable Connector Rebuild Procedures and Drawings.....	28~32

## YEOMANS CHICAGO CORPORATION

Shipping Address:

3905 Enterprise Court  
Aurora, IL 60504

Mailing Address:

P.O. Box 6620  
Aurora, IL 60598-0620

(630) 236-5500 PHONE

(630) 236-5511 FAX

[www.yeomanspump.com](http://www.yeomanspump.com)

## ACCEPTANCE OF SHIPMENT

Thoroughly inspect this equipment before accepting shipment from the transportation company. If any of the goods called for in the bill of lading or express receipt are damaged or the quantity is short, do not accept them until the freight or express agent makes an appropriate notation on your freight bill or express receipt. If any concealed loss or damage is discovered later, notify your freight or express agent at once and request him to make an inspection. We will assist you in collecting claims for loss or damage in shipment; however, this willingness on our part does not remove the transportation company's responsibility in reimbursing you for collection of claims or replacement of material. Claims for loss or damage in shipment must not be deducted from the Yeomans Chicago Corporation (YCC) invoice, nor should payment of the YCC invoice be withheld awaiting adjustment of such claims, as the carrier guarantees safe delivery. If considerable damage has been incurred and the situation is urgent, contact the nearest YCC Representative or the factory for assistance. Please keep a written record of all such communications.

## IMPORTANT

**THOROUGHLY READ ALL INSTRUCTIONS BEFORE SERVICING YCC MOTORS.** YCC cannot be responsible for any damage resulting from failure to comply with these instructions. This motor is not to be operated at conditions nor with liquids other than those stated in the original order acknowledgment without written permission from YCC. Keep this manual handy for ready reference.

An extra motor nameplate is furnished for future reference. This should be retained in a safe place such as the control panel. Information shown on the nameplate is required for ordering replacement parts.

## CAUTION

Surface temperature of the motor enclosure may reach temperatures which can cause discomfort or injury to personnel making accidental contact. Protection should be provided by the user to prevent accidental contact with hot surfaces. Follow all lockout/tagout procedures before servicing.

## WARNING

**MOTOR MAY CONTAIN GAS UNDER PRESSURE DUE TO HIGH TEMPERATURES FROM ABNORMAL OPERATION. DISASSEMBLY MAY CAUSE BODILY INJURY. CONTACT YCC FOR ASSISTANCE.**

## GENERAL NOTES

- 1) **Motor** - YCC Submersible Motors are totally enclosed non ventilated (TENV), of an explosion-proof, tandem seal design, with an oil chamber separate from the motor windings. To insure the integrity of sealing surfaces and explosion-proof fits when servicing these motors, all parts should be handled with utmost care.
- 2) **Wound Stators** -YCC Submersible Motors have stator insulation systems specifically designed for the temperature and electrical ratings involved. If motor failure is analyzed to encompass a winding failure, it is required that a replacement wound stator be ordered from YCC.
- 3) **MODU-CAB<sup>®</sup> Cap & Cable Assembly** – The MODU-CAB<sup>®</sup> cap & cable system is supplied with modular cable units and a modular rail-mounted terminal board. The cap & cable assembly can be removed from the motor in order to perform normal inspection and repairs. Should the cap & cable assembly or individual cable modules be damaged or the integrity of the sealing components be in question, repair or replacement is required. Complete MODU-CAB<sup>®</sup> assemblies and individual cable units are available as replacement parts. Rebuild kits for field repair of the cable modules are also available as replacement parts. When rebuilding the cable modules with non-OEM cable, care should be taken to use only cable meeting original factory specifications and dimensions. When replacing the MODU-CAB<sup>®</sup> assembly or individual cable modules, care should be taken not to nick or damage the o-ring seals. Replace any damaged or nicked o-rings. Please refer to instructions supplied with the replacement parts for complete details.
- 4) *WHEN REPLACEMENT MODU-CAB<sup>®</sup> PARTS ARE REQUIRED, BE SURE TO ORDER FROM YCC USING MOTOR NAMEPLATE IDENTIFICATION NUMBERS.*
- 5) **Hardware** - All hardware is stainless steel and, if necessary, should be replaced with the same type.

## FACTORY MUTUAL RESEARCH APPROVED MOTORS

YCC manufactures both Factory Mutual (F/M) Approved motors and non-F/M Approved motors. F/M motors are explosion proof and approved for Class I, Division I, Groups C and D/T3A. Non-F/M motors are of an explosion-proof design, but do not carry third party approval. The motor nameplate carries the F/M logo when F/M motors are purchased.

The repair of F/M YCC submersible motors by independent repair shops is permissible. However, to maintain the approved status, strict guidelines for the repair must be adhered to. They are as follows:

- 1) YCC must first be notified prior to any work being done to motor, the nature of the work, and who will complete the work.
- 2) No machining, rework, or redesign to any part or assembly is permitted. ***There are no exceptions.***
- 3) All new replacement parts required to reconstruct the motor back to operating condition must be ordered from YCC.
- 4) No changes to or removal of motor nameplates, warning plates, and/or instruction labels is permitted. Replacements are available from YCC. (Damaged plates must be returned to YCC.)

***Disregarding these guidelines will result in voiding the Factory Mutual Research Approved status of the motor.***

***NO CHANGES TO THIS DOCUMENT ARE PERMITTED WITHOUT PRIOR FM APPROVAL.***

## LONG TERM STORAGE INSTRUCTIONS

The equipment is shipped from the factory with adequate protection for transportation in covered trucks, and for indoor storage at the job site for a limited time between receipt and installation. If the equipment is not put into service within 90 days, it should be stored in a cool, clean, and dry indoor location. The equipment should be removed from shipping packaging and inspected prior to storage. To help prevent rusting, any paint scratches or chips incurred during handling should be touched up prior to storage. Store the equipment in the vertical shaft down position.

Electrical cables must be properly supported and protected from moisture. The rotating assembly must be spun for approximately one (1) minute monthly to insure proper distribution of lubricant and to prevent damage to the shaft, bearings or seals.

## INSTALLATION NOTES

Maximum submergence of motor is not to exceed 150 feet in depth and/or 150 P.S.I. working pressure at the motor lower seal.

Thermal Protectors (Leads marked P1 and P2) must be connected. See Figure 1, Page 14.

Moisture Sensing Probes (Leads marked W1 and W2) must be connected. See Figure 2, Page 14.

Check power supply against final nameplate connection voltage. This equipment is intended to operate using a supply of quality power with normally accepted characteristics of voltage unbalance, voltage variations, expected number of voltage sags/interruptions and harmonic distortion levels. The IEEE and the International Electrotechnical Commission (IEC) have developed standards to provide further guidance regarding these areas.

When installing pump or other machine to motor shaft, care must be taken to properly fit shaft and key. If required, the impeller hub should be heated slightly before sliding it onto the shaft. **UNDER NO CIRCUMSTANCES SHOULD THE IMPELLER BE DRIVEN ON BY POUNDING. THIS WILL DAMAGE THE SEALS AND BEARINGS.** The key must be fit to shaft keyway to avoid impeller from riding on key. The fastener must employ locking means to prevent loosening. When fastener is removed, it is recommended fastener be replaced with a similar device available from YCC.

When the submersible motor leaves the factory it is ready for installation, however, during shipping and handling, fasteners may loosen. Verify tightness before installation. No further adjusting, venting or oil filling is required. The motor will operate successfully when the following conditions are met:

Voltage variation: 10% above or below nameplate data.

Frequency variation: 5% above or below nameplate data.

Voltage unbalance: 1% maximum between any two (2) incoming power legs.

Performance within these ranges will not necessarily be the same as the established performance at exact rated voltage and frequency.

The motor should be rechecked for proper rotation on initial start-up, prior to installation. All 3-phase submersible pump motors will operate in either direction of rotation. To reverse direction of a 3-phase motor, interchange any two motor leads at the starter. All single phase motors are clockwise rotation only and cannot be reversed.

A lifting bail is supplied for the purpose of installation and servicing. **DO NOT USE MOTOR CABLES FOR LIFTING. THIS WILL RESULT IN PERMANENT DAMAGE TO THE CAP AND CABLE ASSEMBLY AND WILL VOID THE WARRANTY.** Normal care should be exercised to prevent mechanical damage to the seal, the frame, and the insulated cable.

## **CAUTION**

Control leads should not be installed in the same conduit as power leads. Induced voltage can cause false moisture detection signals. Additionally, junction boxes installed inside wet wells are subject to moisture and condensation. These conditions may produce false moisture detection warnings.

## **START-UP**

YCC Submersible motors are designed to run continuously in water or 15 minutes in air. During normal operation, the water level should not be lower than the top of the stator housing of the motor.

YCC Dry Pit Submersible motors are nameplated Continuous In Air, which is a submersible motor for Dry Pit Submersible service. When the motor nameplate indicates CONT IN AIR the pump is designed to operate continuously either in air or submerged.

The unit is designed to protect all power connections against moisture. All YCC Submersible Motors have a lead connection chamber. Three phase, dual voltage motors have 9 stator leads. In addition, all submersible motors have 2 thermal protector leads and 2 moisture sensing probe leads in this chamber.

Leads are tagged for easy identification. Appropriate connection diagrams can be found on pages 15 and 16. Some motors can be connected for either high or low voltages. (Some motor ratings are built as single voltage units and as such are not re-connectable.) For high temperature applications: Temperature resistant Voltrex sleeves protect leads and the cap and cable assembly may differ from that shown in this instruction.

## **MAINTENANCE**

With proper installation and employment of monitoring devices, frequent inspection of motor seals is not required. Should a malfunction occur, the motor has been equipped with a moisture detection system and thermal protection that will provide advance warning of impending failure, allowing the user to plan corrective maintenance before total failure occurs.

## THERMAL PROTECTION SYSTEM

### IMPORTANT

***YCC SUBMERSIBLE MOTORS ARE EQUIPPED WITH THERMAL PROTECTION DEVICES. FAILURE TO PROPERLY CONNECT OR UTILIZE THIS SYSTEM VOIDS THE MOTOR WARRANTY.***

Thermostat leads marked P1 and P2 should be connected in series with the stop button on the 3-wire pilot circuit of the magnetic motor controller, so that the thermostat will open the circuit before dangerous temperatures are reached. Refer to Figure 1, Page 14, for wiring diagram of Thermal Protector.

#### **WARNING**

***MOTOR CONTROLLER MAY HAVE AUTOMATIC OR MANUAL OVERLOAD RESET. DISCONNECT ALL POWER LEADS TO MOTOR WHEN PERFORMING ANY WORK ON MOTOR. A MANUAL, MOMENTARY START SWITCH IS RECOMMENDED TO PREVENT AUTOMATIC RESTART OF THE MOTOR WHEN THERMOSTAT RESETS.***

If current through the thermostats exceeds the values listed in Table 1, an intermediate control circuit relay must be used to reduce the current or the thermostats will not work properly.

Volts (VAC)	Continuous Amperes	Inrush Amperes
110-120	3.0	30
220-240	1.5	15
440-480	0.75	7.5
550-600	0.6	6.0

### MOISTURE DETECTION SYSTEM

***IMPORTANT YCC SUBMERSIBLE MOTORS ARE EQUIPPED WITH MOISTURE DETECTION DEVICES. FAILURE TO PROPERLY CONNECT OR UTILIZE THIS SYSTEM VOIDS THE MOTOR WARRANTY.***

Moisture sensing probe leads marked W1 and W2 must be used in conjunction with an induction relay or similar device. This device will detect moisture entering the oil chamber due to leakage of the lower seal and/or a breach of the stator housing. When properly connected to a warning device, the moisture detection system will provide notification of needed corrective maintenance. Refer to Figure 2, Page 14, for a typical wiring diagram of Moisture Sensing Circuit. The integrity of the system requires periodic testing. It should be checked every month by the test button on the relay, or by measuring the resistance of the moisture sensing circuit.

#### **WARNING**

***CONTROL LEADS SHOULD NOT BE INSTALLED IN THE SAME CONDUIT AS POWER LEADS. INDUCED VOLTAGE CAN CAUSE FALSE MOISTURE DETECTION SIGNALS.***

## TEST PROCEDURES

### Moisture Seal Probe Test

A normally closed push-button and neon indicating lamp may be provided as a means of checking the moisture sensing components. When the push-button is depressed, the indicating lamp will be illuminated to indicate: A) power is supplied to the control, B) the control is operative, C) wiring to the moisture sensing probes in the motor is intact. If a test button is not supplied, the integrity of the circuit may be checked with an ohmmeter by first disconnecting W1 and W2 from the relay. To avoid inaccurate readings, it is important to measure the resistance across the leads to the moisture seal probe and NOT across the relay. Measured resistance should be 330,000 ohms ( +/- 10%). Measured resistance below this level could indicate a moisture breach. Measured resistance above this level could indicate an interruption in the circuit and/or wiring.

### Signal Device(s) for Moisture Notification

The signal device may be audible (bell, buzzer, horn or siren) or visible (incandescent or neon lamp) or both.

### Megger Test

Meggers are normally used for trend analysis, whereby newly installed electrical equipment is measured to establish a base of values in resistance, which are recorded along with numerous other relevant variables. Thereafter, readings are periodically taken and recorded along with temperature, moisture, and the length of time the megger was connected to obtain readings. This procedure must be continued for an extended period of time in order to determine that the declining rate of insulation breakdown is not accelerating at an unacceptable level. This test should be taken between the power leads and ground and **NEVER ACROSS THE MOISTURE DETECTION OR THERMAL PROTECTION CIRCUITS.**

With periodic monitoring of the moisture-sensing probe as part of a regular schedule of preventive maintenance, it is unnecessary to perform a megger test. However, if a megger test is performed, a resistance of 2 megohms or less indicates maintenance is needed.

### System Operation

**SYSTEM OPERATION** - It is recommended that upon indication (by warning light, etc.) of lower seal failure that the motor is removed from the installation and the fluid and lower seal is replaced as soon as possible. If reconditioning is not performed within a 30-day period it is recommended that the upper seal and thrust bearing be thoroughly inspected and replaced if required. Disregard of this warning and/or failure to perform this inspection may result in catastrophic failure and will void the warranty.

When ordering parts or reporting trouble, please provide complete motor nameplate data.



## DISASSEMBLY INSTRUCTIONS

**WARNING**  
**MOTOR MAY CONTAIN GAS UNDER PRESSURE DUE TO HIGH TEMPERATURES FROM OPERATION.**  
**DISASSEMBLY MAY CAUSE BODILY INJURY.**

### Electrical Repairs

Electrical repairs such as stator repair and/or replacement, or servicing of thermal protectors may be accomplished without disturbing the rotating assembly (i.e. rotor, thrust bearing housing, lower seal housing).

Refer to Cross Section Drawing (Figures 5, 6 & 7, Pages 17, 18 & 19).

- 1) Remove cap screws (26) securing MODU-CAB® assembly (9)
- 2) Disconnect all leads and grounding wire. Remove MODU-CAB® assembly.
- 3) Remove bolts (23) securing thrust bearing housing (5) to stator housing (7). Using top lifting bail (54), lift stator assembly, being careful not to catch moisture probe leads (32) in wire channel.
- 4) Remove lifting bail (54) and lifting bail hardware, along with all hardware connecting the radial bearing housing (8) to the stator housing (7). NOTE: Pay particular attention to the location of lifting bail so that it is reassembled in the same position.
- 5) Remove radial bearing housing (8) if necessary.

### Mechanical Repairs

#### **Inspecting or Draining Oil:**

Lower seal cavity is oil filled. Oil can be drained by removing either pipe plug (25) or (40).

#### **Inspecting Lower Seal:**

- 1) Place motor with output shaft in up position.
- 2) Remove lower seal snap ring (12).
- 3) Remove lower seal rotating element (13).
- 4) Thoroughly clean the recess and visually inspect seal. If mating faces do not show excessive wear, replacement is not required.

#### **Inspecting Upper Seal:**

- 5) Remove pipe plug (25) and drain oil while in shaft up position. Remove lower seal as described above.
- 6) Remove cap screws (22) from thrust bearing housing (5) and remove lower seal housing (4).
- 7) Remove upper seal snap ring (15) and upper seal rotating element (16).
- 8) Thoroughly clean the chamber and visually inspect seal. If mating faces do not show excessive wear, replacement is not required.

#### **Thrust Bearing Replacement:**

- 9) Rotate motor to output shaft in down position.
- 10) Remove MODU-CAB® assembly (9), stator housing (7), and stator (2) (Refer to Electrical Repairs Disassembly Items 1-3).

11) FOR 180, 210, & 250 FRAMES: Remove thrust bearing retaining ring (6). Grasp rotor (1) below radial bearing (11) and lift rotor/shaft assembly.  
FOR 320 & 360 FRAMES: Remove cap screw (46) and lift thrust bearing cap (6). Grasp rotor (1) below radial bearing (11) and lift rotor/shaft assembly.

12) Disconnect moisture sensing probe lead wires (32) at probes (21).

13) FOR 180, 210, & 250 FRAMES: Remove thrust bearing snap ring (44).  
FOR 320 & 360 FRAMES: Remove locknut and lock washer (45).

14) Using a suitable bearing puller, remove thrust bearing (10).

**Final Disassembly:**

15) Remove moisture sensing probes (21) and resistor (37) if necessary.

16) For complete disassembly refer to Electrical Repairs Disassembly, Items 4-5.

17) Using suitable bearing puller, remove radial bearing (11) if necessary.

18) Remove stationary seats of the upper (17) and lower (14) seals.

**NOTE:** Rotor & Shaft assembly cannot be further disassembled. Stators on 320 and 360 frames are secured in the housings by a pin or set screw located approximately at the center of the stator housing. The pin or set screw is sealed and covered by a pipe plug and cannot be serviced or removed.

## REASSEMBLY INSTRUCTIONS

- 1) FOR 180, 210, & 250 FRAMES: Rotating Assembly-- Assemble radial bearing (11), thrust bearing snap ring (44) and thrust bearing (10) to rotor/shaft assembly.

FOR 320 & 360 FRAMES: Rotating Assembly-- Assemble radial bearing (11), thrust bearing cap (6), thrust bearing (10), lock washer and locknut (45) to rotor/shaft assembly. Pay particular attention to orientation of thrust bearings. Install with the wide outer races facing each other as shown on the attached drawing.

### CAUTION

**WHEN INSTALLING BALL OR ROLLER BEARINGS, PRESS ONLY AGAINST INNER RACES OF BEARINGS. PRESSING ON OUTER RACES WILL DAMAGE ROLLING ELEMENTS AND DAMAGE THE BEARING. PRESS EVENLY ON BEARING INNER RACE, USING EXTREME CARE NOT TO SCORE SHAFT.**

It may be necessary to heat bearings to facilitate installation due to close tolerance fits. Bearings may be heated by either of the following methods:

**OIL BATH:** Accomplished by submerging bearing in a tank of oil having a high flash point. The bearing should be suspended so as not to be in contact with the heat source, for 20 to 30 minutes at a temperature of approximately 200°F. Oil temperature must not exceed 250°F.

**INDUCTION HEATING:** Accomplished by applying heat directly to the bearing (i.e., commercially available induction bearing heater). Extreme caution must be exercised to insure that bearing temperature does not exceed 200°F.

The bearings should be quickly installed and positioned squarely against mating face while it is still hot, and secured with appropriate retaining ring or locknut. Retighten locknut after bearing has cooled.

### WARNING

**SUITABLE PROTECTIVE CLOTHING (I.E. GLOVES) MUST BE WORN WHEN HANDLING HEATED COMPONENTS.**

- 2) Place o-rings (18), (19) & (28) on their register fits. Lightly coat all fits with a suitable lubricant (such as that listed on page 13). Alternatively, grease may be substituted (not excessive).
- 3) Thrust Bearing Housing Assembly--
  - A) Coat moisture sensor probe (21) pipe threads with sealant and screw into place, making sure they are tight. Clean excessive sealant from thrust bearing housing (5).
  - B) Pre-pack thrust bearing (10) 2/3-3/4 full of lithium based grease. Do not over grease. FOR HI-TEMP APPLICATIONS: Use Chempet B-2 Grease NLGI Grade 2 (Part # C95-3-15)
  - C) Lightly lubricate upper seal stationary seat o-ring(17) with recommended seal lubricant (page 13). Make certain lapped face is exposed. Now, using a suitable pressing tool, carefully press upper seal stationary seat into thrust bearing housing (5) until properly positioned.
  - D) *FOR 180, 210, & 250 FRAMES:* Lower reassembled rotating assembly (Re-assembly Instruction 1, above) into thrust bearing housing (5) and secure thrust bearing retaining ring (6) in thrust bearing housing (5).  
*FOR 320 & 360 FRAMES:* Lower reassembled rotating assembly (Re-assembly Instruction 1, above) into thrust bearing housing (5) and secure thrust bearing cap (6) to thrust bearing housing (5) with cap screws (46).

E) Attach resistor (37) and lead wires (32) marked W1 and W2 to probes (21). Re-install stator (2) and lower stator housing (7) over rotating assembly, pulling W1 and W2 lead wires (32) through cored channel in housing. Bolt stator housing (7) to thrust bearing housing (5) with cap screws (23), making sure the o-ring (18) is not damaged and is properly seated.

4) Top Cap/Radial Assembly--

A) Pre-pack radial bearing (11) 2/3 to 3/4 full of lithium based grease such as Mobilux EP2 or equal. Do not over-grease. FOR HI-TEMP APPLICATIONS: Use Chempet B-2 Grease NLGI Grade 2 (YCC Part # C95-3-15)

B) Assemble radial bearing housing (8) to stator housing (7) by pulling all lead wires through one of the cored opening in radial bearing housing (8). Make sure o-ring (19) is seated properly before tightening all hardware previously removed.

C) Replace lifting bail (54) to original position and secure with fastening hardware.

5) Lower Seal/Mounting Flange Assembly--

A) Place motor assembly with output shaft in up position. Thoroughly clean seal cavity and probes. Lightly lubricate rubber parts of upper seal rotating element (16) and shaft (3) with recommended seal lubricant. Slide complete upper seal rotating element (16) onto shaft (3). Firmly push into position and install upper seal snap ring (15) on shaft (3) using a suitable tool. Turn shaft by hand to make sure seal is properly seated.

B) Reinstall lower stationary seat (14) and rubber mounting cup, making sure it is properly seated. Follow steps outlined in Paragraph 3) C) on previous page.

C) Assemble lower seal housing (4) to thrust bearing housing (5) and secure with cap screws (22). Make sure o-ring (28) is properly seated before tightening. Thoroughly clean seal cavity. Complete lower seal rotating element (13) and lower seal snap ring (12) following the procedure outlined in Paragraph 5) A) above. When complete, turn shaft by hand to make sure seals are properly seated.

D) Add required quantity of recommended oil to lower seal cavity (Refer to Table 2 for recommended oil quantities). This can be accomplished with the output shaft in the up position. Use pipe plugs (40) (one for filling and one for venting); or, in a shaft down position use plugs (25) similarly. The oil level should be checked after assembly is complete and motor is returned to shaft down position. Oil level should be even with the bottom of upper pipe plug (25).

6) MODU-CAB<sup>®</sup> assembly --

A) Rotate motor to output shaft in down position.

B) Thoroughly clean all o-ring fits. Place o-ring (20) over fit and lightly coat with grease (not excessive).

C) Reconnect power and control wires using applicable connection diagram on pages 15 & 16.

D) Secure MODU-CAB<sup>®</sup> assembly (9) to radial bearing housing (8) using screws (26), making sure o-ring (20) is properly seated.

TABLE 2		TABLE 3		
RECOMMENDED OIL QUANTITIES		RECOMMENDED OIL		
			<b>MANUFACTURER</b>	<b>BRAND NAME</b>
<b>MOTOR FRAME</b>	<b>QUANTITY</b>	Standard	Petro Canada	Petro Canada 10W
180	2.4 QTS		Citgo	Citgard 10W
210	4.0 QTS	Food-Grade	Petro Canada	Purity FG White Mineral Oil
250	5.9 QTS		Witco	Freezene Heavy
320	8.7 QTS			
360	6.6 QTS			

**\*\* Recommended Grease for Bearings: CITGO Lithium EP-2 or equivalent**

### MAINTENANCE DATA FOR MECHANICAL SEALS

Applicable Products: YCC Submersible Motors

Applicable Seals: Type 21 or equal.

MOTOR FRAME	SIZE	
	UPPER SEAL	LOWER SEAL
180	1-3/4"	1-1/2"
210	2"	1-3/4"
250	2-1/4"	2-1/8"
320	3-1/4"	3"
360	3-1/2"	3-1/4"

Cleaning Solvent: Denatured Ethyl Alcohol Solvent  
Formula CDA 19

Seal Installation Lubricant: Water or water based seal installation lubricant such as P-80® Rubber Lubricant. Do not use oil or grease as a seal lubricant

**IMPORTANT**

**YCC Submersible Motors are equipped with thermal protection & moisture detection devices. Failure to properly connect or utilize these systems voids the motor warranty.**

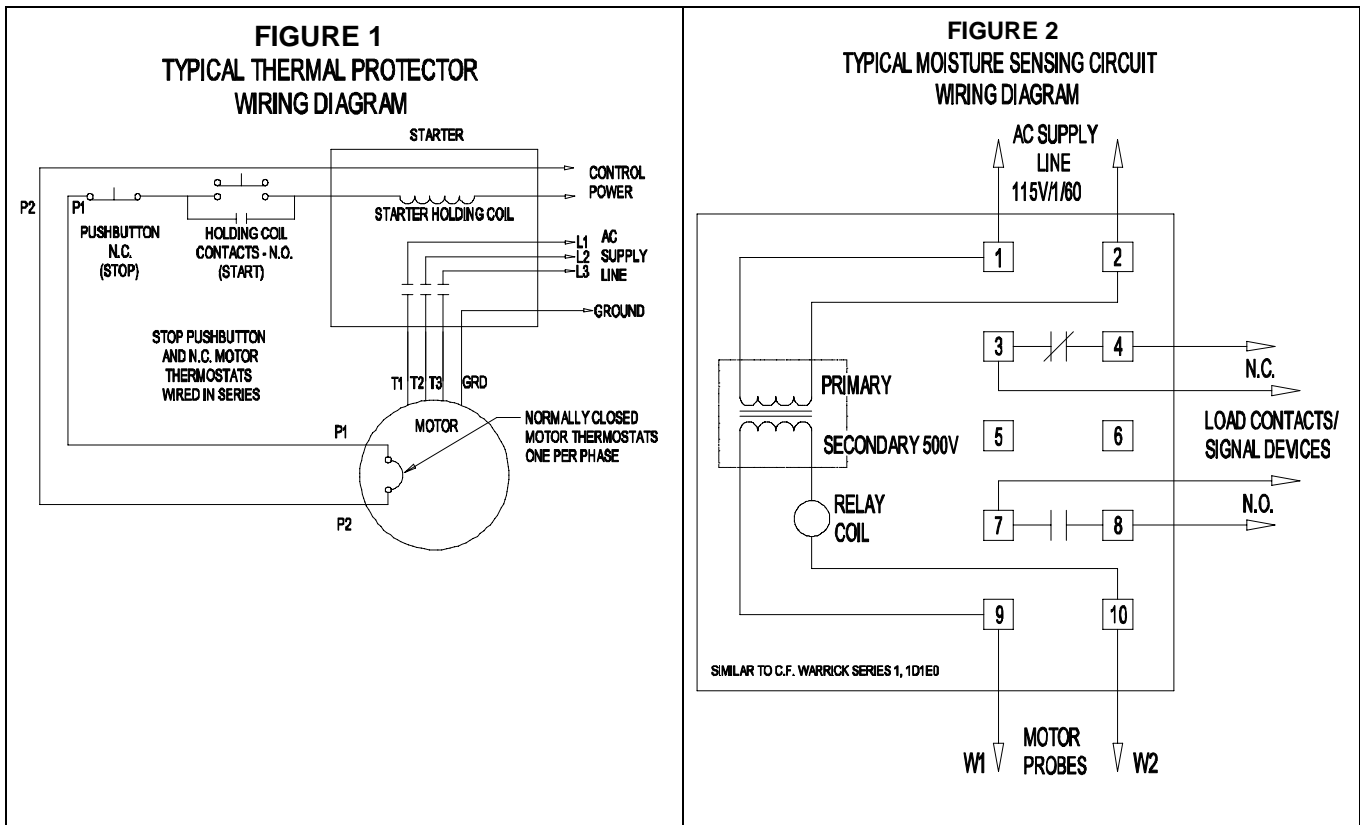

**Table 4 - Lead Color Coding**

		<b>Black Lead</b>	<b>White Lead</b>	<b>Red Lead</b>	<b>Orange Lead</b>	<b>Green Lead</b>
Power Cable	Polyphase	T1	T2	T3	-	Ground
Control Cable	All	P1	P2	W1	W2	-

**FIGURE 3**

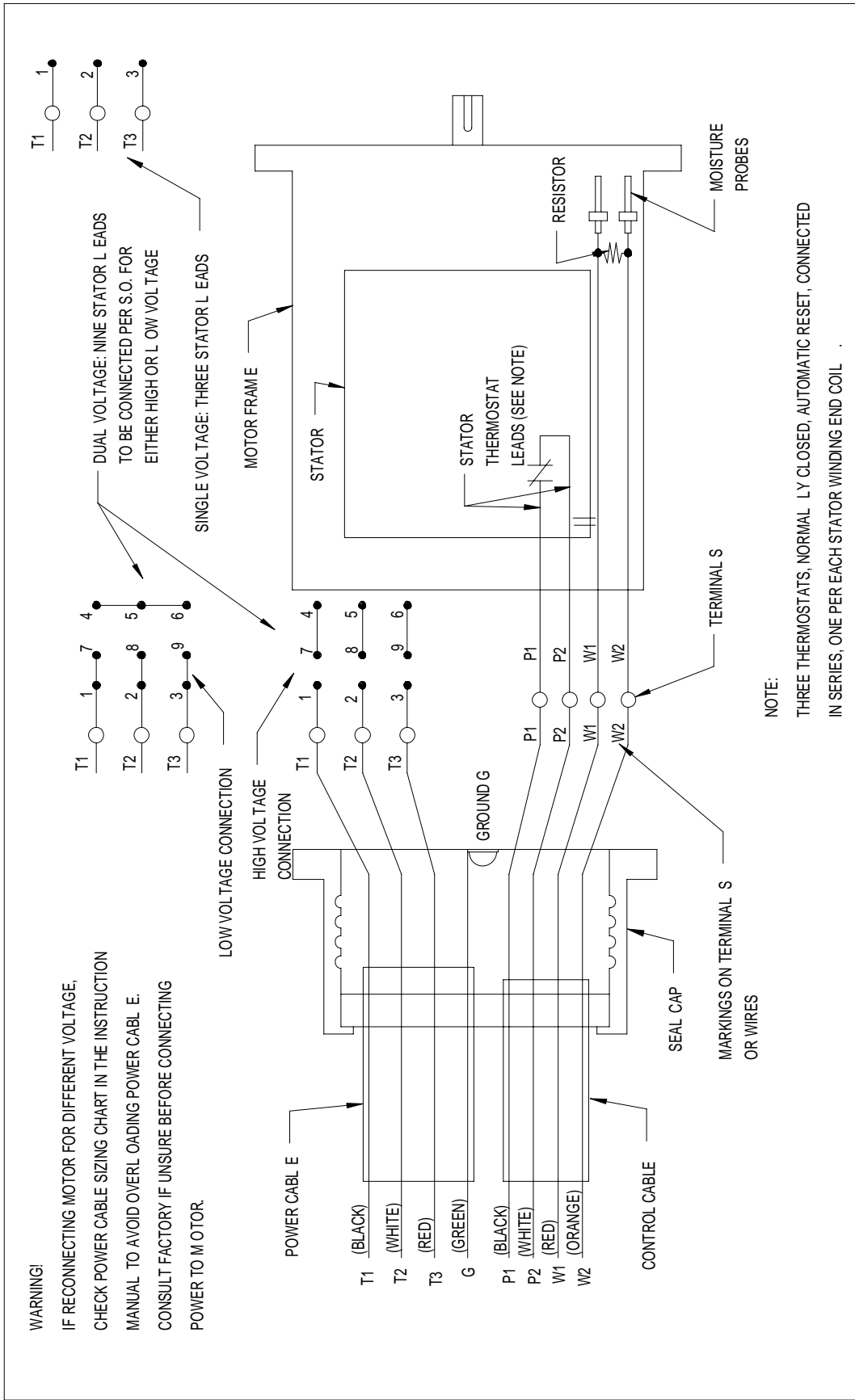

<p><b>STANDARD MACHINE TOLERANCES UNLESS OTHERWISE SPECIFIED</b></p> <p>ALL DIMENSIONS IN INCHES</p> <p>±0.12 UNFINISHED                  ±0.06 ONE PLACE DECIMAL                  ±0.015 TWO PLACE DECIMAL                  ±0.005 THREE PLACE DECIMAL                  ±0.0005 FOUR PLACE DECIMAL                  ±.1/64 FRACTION                  ±.002 TIR // 0.002 TIR                  .002 TIR .002 TIR                  RADIUS/CHAMFER OUTSIDE CORNER .035                  INSIDE CORNER R.035 MAX.</p>		<p><b>REVISIONS</b></p>	
<p>THIRD ANGLE PROJECTION</p> <p>MATERIAL AS SPECIFIED</p> <p>WEIGHT - lbs/kg</p> <p>SCALE NTS</p> <p>ORDER No.</p>		<p>This drawing is the property of Yeomans Chicago Corporation and is submitted in confidence and shall not be reproduced, copied, nor disclosed to others without the permission of the drawing office.</p> <p>DRAWN BY: ASZ DATE: 1-31-05</p> <p>CHECKED BY:</p>	
<p>YEOMANS CHICAGO CORPORATION                  AURORA, IL, USA</p>		<p>PART &amp; DWG. NO. <b>A 112394</b></p>	
<p>PART SEAL CAP &amp; MOTOR WIRING DIAGRAM TYP. FOR 3-PH, DUAL VOLTAGE &amp; SINGLE VOLTAGE</p>		<p>MODEL PATTERN</p>	

FIGURE 4

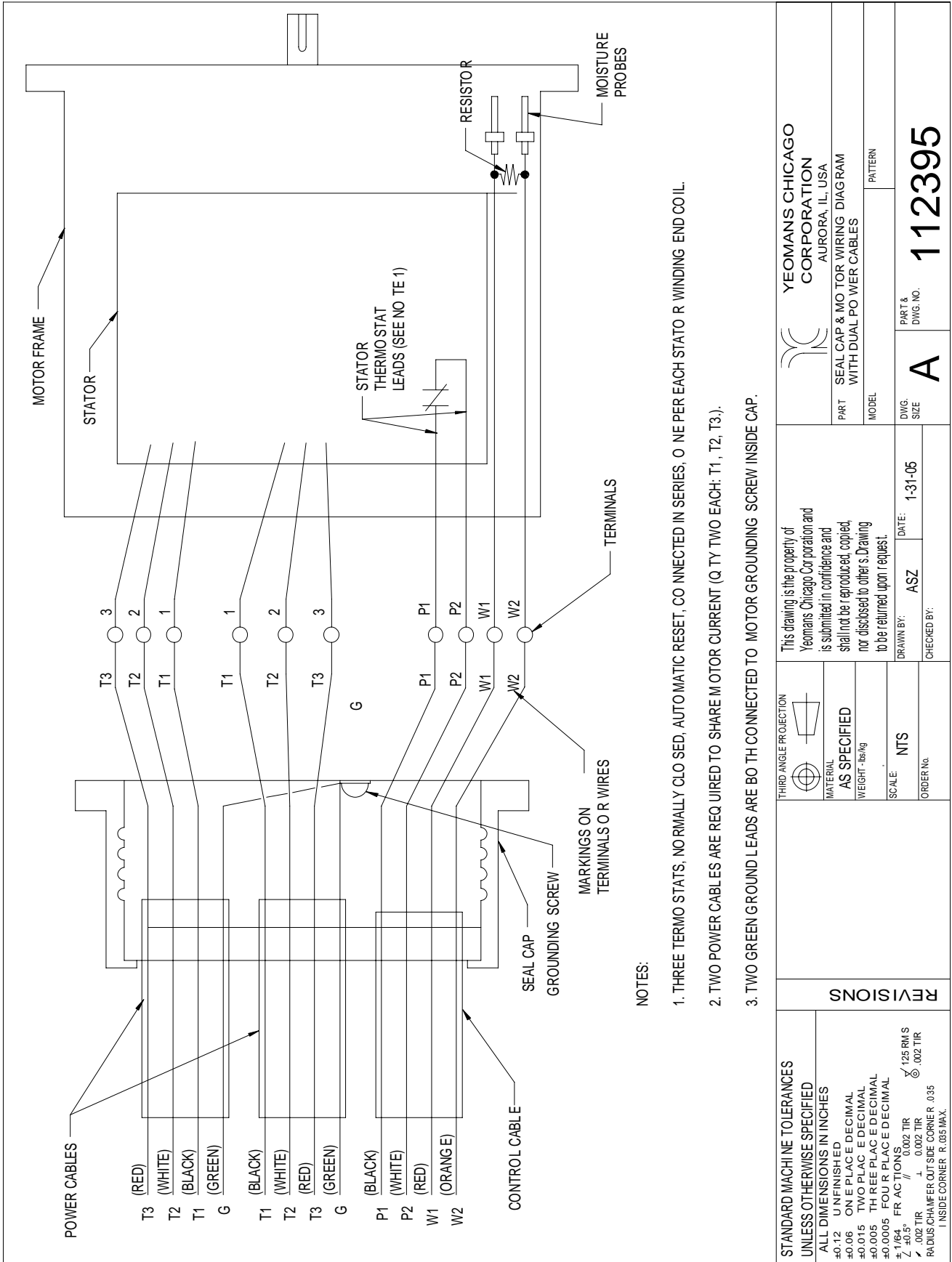

NOTES:

1. THREE THERMO STATs, NORMALLY CLOSED, AUTOMATIC RESET, CONNECTED IN SERIES, ONE PER EACH STATOR WINDING END COIL.
2. TWO POWER CABLES ARE REQUIRED TO SHARE MOTOR CURRENT (QUANTITY TWO EACH: T1, T2, T3).
3. TWO GREEN GROUND LEADS ARE BOTH CONNECTED TO MOTOR GROUNDING SCREW INSIDE CAP.

STANDARD MACHINE TOLERANCES UNLESS OTHERWISE SPECIFIED	
ALL DIMENSIONS IN INCHES	
±0.12 UNFINISHED	✓125 RMS
±0.06 ONE PLACE DECIMAL	0.002 TIR
±0.015 TWO PLACE DECIMAL	0.002 TIR
±0.005 THREE PLACE DECIMAL	0.002 TIR
±0.0005 FOUR PLACE DECIMAL	0.002 TIR
±1/64 FRACTIONS	0.002 TIR
✓0.02 TIR	0.002 TIR
✓0.002 TIR	0.002 TIR
RADIUS CHAMFER OUTSIDE CORNER .035	
INSIDE CORNER R.035 MAX.	

REVISIONS

DATE	BY	DESCRIPTION
1-31-06	ASZ	

This drawing is the property of Yeomans Chicago Corporation and is submitted in confidence and shall not be reproduced, copied, or disclosed to others. Drawing to be returned upon request.	
DRAWN BY: ASZ	DATE: 1-31-06
CHECKED BY:	

<p>YEOMANS CHICAGO CORPORATION AURORA, IL, USA</p>	
PART	SEAL CAP & MOTOR WIRING DIAGRAM WITH DUAL POWER CABLES
MODEL	PATTERN
DWG. NO.	112395
SIZE	A
PART & DWG. NO.	



FIGURE 5

# CROSS SECTION AND PARTS IDENTIFICATION DRAWING

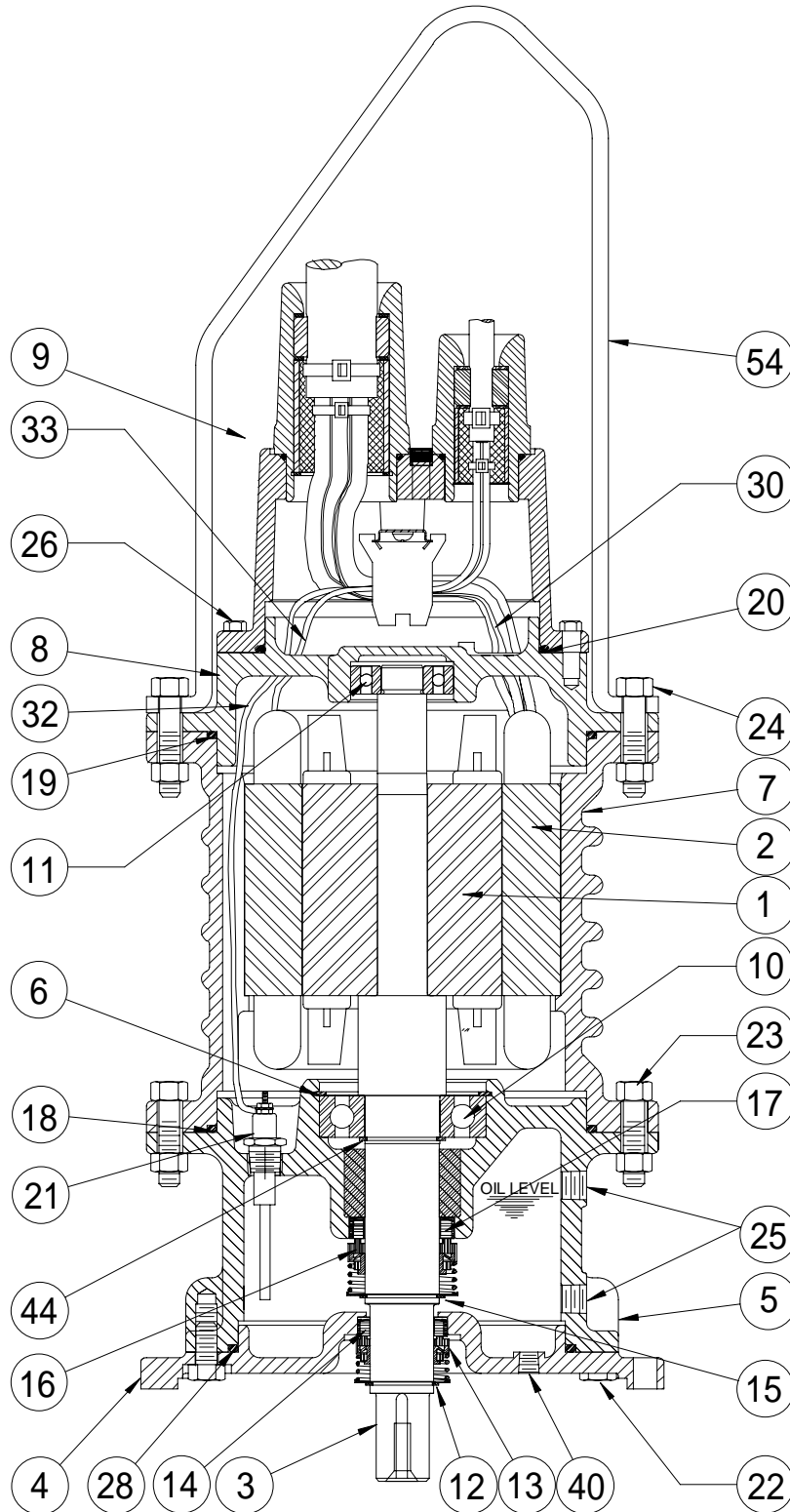

TYPICAL 180, 210 & 250 FRAME

FILE NAME: 109568

04/18/05

FIGURE 6

# CROSS SECTION AND PARTS IDENTIFICATION DRAWING

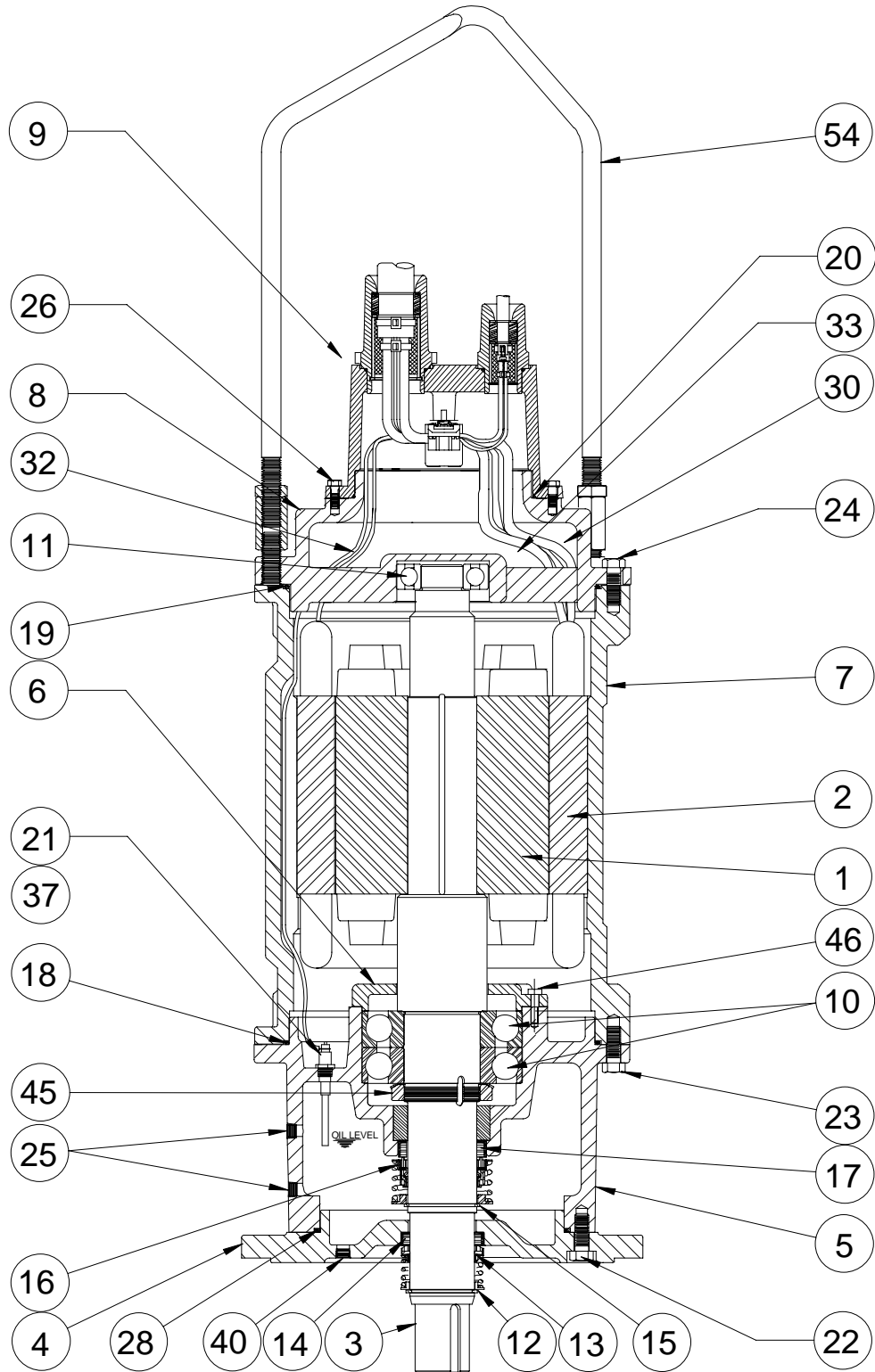

TYPICAL 320 & 360 FRAME

FILE NAME: 110497

04/18/05

FIGURE 7

# CROSS SECTION AND PARTS IDENTIFICATION DRAWING

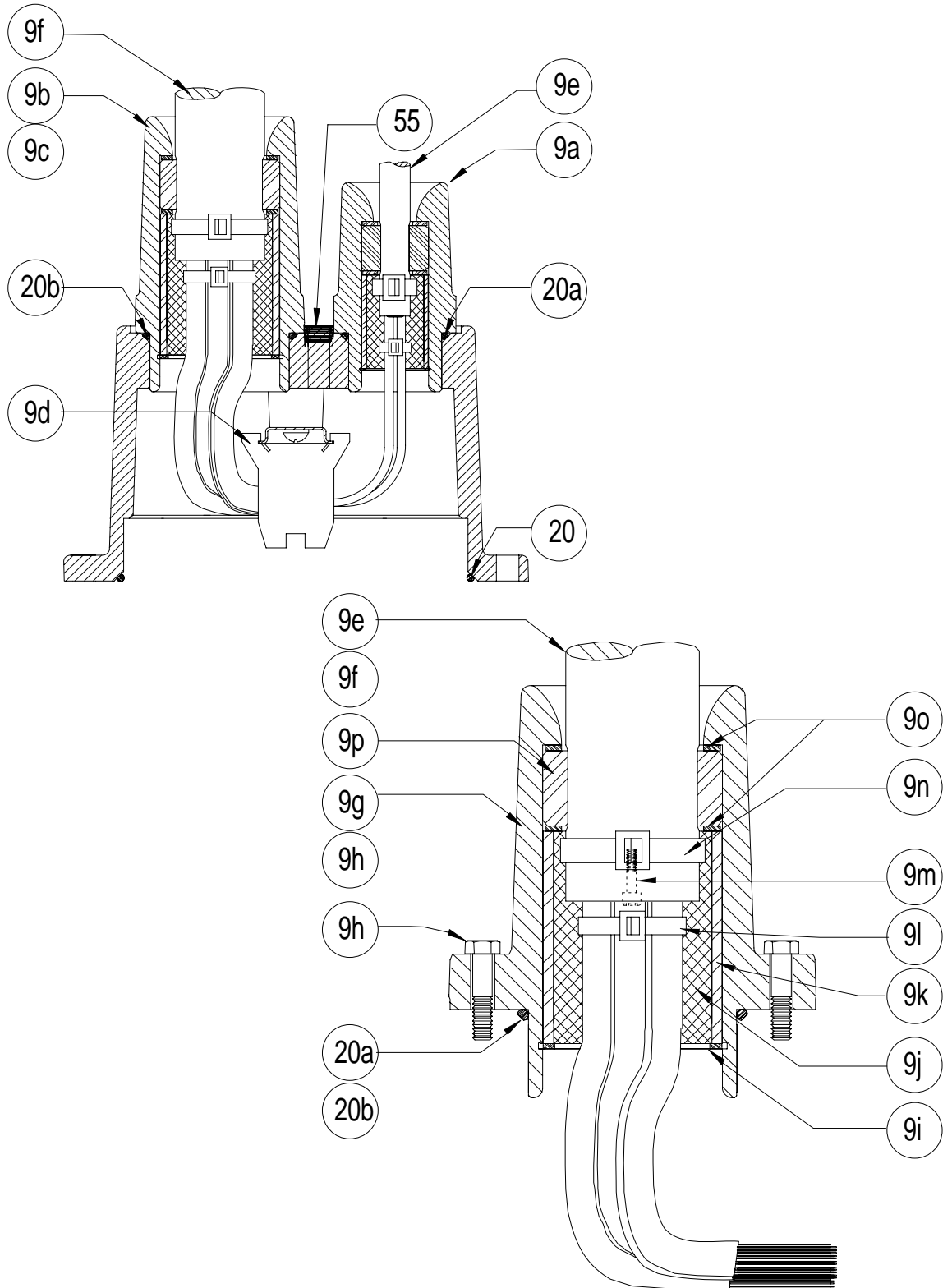

TYPICAL MODU-CAB<sup>®</sup> ASSEMBLY

**FIGURE 8 – PARTS LIST FOR FIGURES 5,6 & 7**

NO.	DESCRIPTION
1	ROTOR
2	STATOR
3	SHAFT
4	LOWER SEAL HOUSING
5	THRUST BEARING HOUSING
6*	THRUST BEARING CAP OR SNAP RING
7	STATOR HOUSING
8	RADIAL BEARING HOUSING
9	MODU-CAB® CAP & CABLE ASSEMBLY
9a	CABLE CONNECTOR ASSEMBLY - CONTROL
9b	CABLE CONNECTOR ASSEMBLY - POWER 1
9c**	CABLE CONNECTOR ASSEMBLY - POWER 2
9d	TERMINAL ASSEMBLY
9e	CONTROL CABLE
9f	POWER CABLE
9g	CONNECTOR BODY - CONTROL
9h	CONNECTOR BODY - POWER
9i	RETAINING RING
9j	SEALING COMPOUND
9k	SLEEVE
9l	CABLE TIE
9m	CAP SCREW-NYLON
9n	CABLE TIE
9o	WASHER (2)
9p	GROMMET
9q	CAP SCREW
10*	THRUST BEARING
11*	RADIAL BEARING
12	LOWER SEAL SNAP RING
13	LOWER SEAL ROTATING ELEMENT
14	LOWER SEAL STATIONARY SEAT
15	UPPER SEAL SNAP RING
16	UPPER SEAL ROTATING ELEMENT
17	UPPER SEAL STATIONARY SEAT
18	O-RING, THRUST BEARING HOUSING
19	O-RING, STATOR HOUSING
20	O-RING, MODU-CAB® TO RADIAL BRG. HSNG.
20a	O-RING, CONTROL CABLE CONNECTOR
20b	O-RING, POWER CABLE CONNECTOR
21	MOISTURE PROBES
22	SOCKET HEAD CAP SCREW
23	HEX HEAD/SOCKET HEAD CAP SCREW
24	HEX HEAD CAP SCREW
25	PIPE PLUG
26	HEX HEAD CAP SCREW
28	O-RING, LOWER SEAL HOUSING
30	POWER WIRING LEADS
32	PROBE WIRING LEADS
33	THERMAL PROTECTOR LEADS
37	RESISTOR (ACROSS PROBES 21)
40	DRAIN PLUG
44**	SNAP RING - THRUST BEARING
45**	LOCK NUT AND WASHER
46**	HEX HD CAP SCREW
54	LIFTING BAIL
55	PIPE PLUG

\*NOTE - NOT APPLICABLE TO ALL FRAMES.

## ADDENDUM MECHANICAL SEAL INSTRUCTION – SUBMERSIBLE

The mechanical seals used on motors manufactured by YCC are purchased commercially from various suppliers that make interchangeable seals. The most common types are called the John Crane Type 21, Pac-Seal/Flowserve Type 21-31, and the Burgmann MG9. These seals applied in YCC motors function interchangeably with some minor changes to the mounting details. **DO NOT ASSUME A REPLACEMENT SEAL MOUNTS IDENTICALLY TO AN EXISTING SEAL.** The retainers for all seals have been updated to accommodate different seals and springs. Some seals use a spring holder, which looks like a thin washer, some use a retaining ring alone. The replacement seal is supplied with the correct retaining components. Note the conical spring and its orientation.

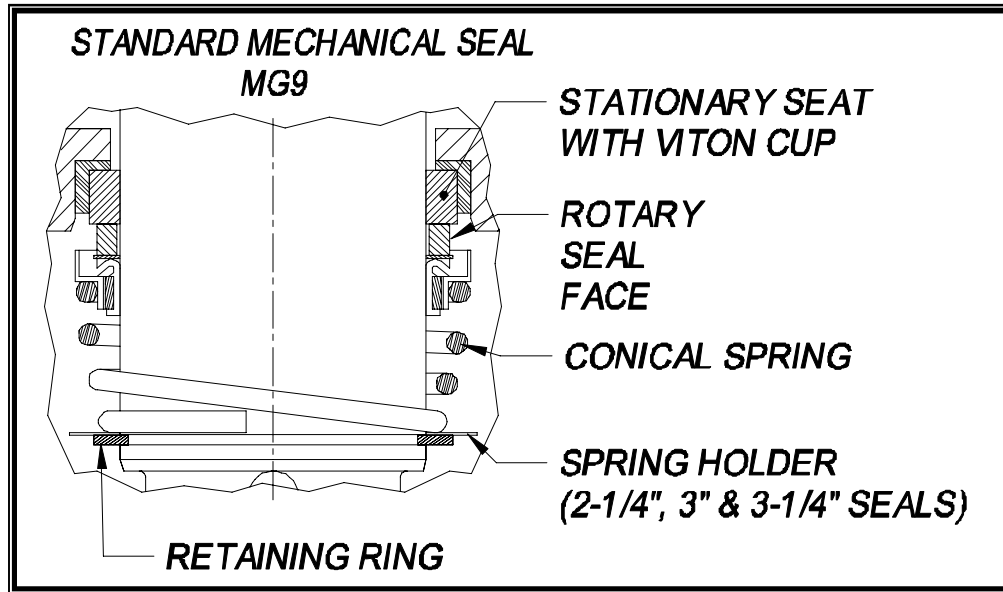

Note: Protect lapped seal faces from contamination or damage during handling and installation. Never use grease or oil as a seal installation lubricant. Oil, grease or dirt on the seal faces may cause leakage. The seal chamber is oil filled at the factory. Take suitable precautions to collect spillage and avoid injury from spray if pressure causes oil to spray when motor is opened.

1. Disassemble pump to expose seal. Lower seal housing will need to be removed to service upper seal. Note assembly and mounting of existing seal. New seal should mount similar but may require additional components such as spring holder or different retaining ring.
2. Carefully remove old seal rotary and stationary components taking care not to damage shaft or housing bore.
3. Clean shaft and housing bore with very fine emery cloth to remove rust and burrs, but avoid making flat spots or reducing the shaft diameter. Clean Shaft and housing bore with suitable solvent.
4. Lubricate the shaft and housing bore and the seal's Viton elastomer components only with water based seal lubricant. Seal faces should not be lubricated.
5. Press stationary seal seat firmly into housing bore. Protect seal face with plastic or cardboard.
6. Check both seal faces for contamination by lubricant or particles. Slide rotary seal components by hand pressure along shaft to insure completely parallel contact with stationary seat. Make sure spring properly engages step on rotary seal and opposite end of spring either rests against spring retainer or sits on the retaining ring. See sketch above.
7. Reassemble motor and pump replacing any components supplied in kit if applicable.
8. When pump is started, submersible wet pit type pumps will vent and purge air pockets automatically without intervention. Never run pump dry.

## YCC STANDARD SUBMERSIBLE MOTOR DATA – 4 POLE

H.P.	Full Load RPM	Frame Size	Nominal Eff % @ *			Nominal Power Factor % @			Amps @ 460V		KVA Code Letter	Full Load Torque (Ft Lbs)	% Full Load Torque		Power Cable		Control Cable			
			Full Load	3/4 Load	1/2 Load	Full Load	3/4 Load	1/2 Load	Full Load	Locked Rotor			Locked Rotor	Break-down	AWG Size	O.D. ** (in.)	AWG Size	O.D. ** (in.)		
0.5	1732	140	55.7	50.1	41.1	75.6	69.3	61.2	1.1	6.1	L	1.5	313	368	#16	0.57	Not Applicable - Single Cable Used			
0.75	1733	140	63.9	58.9	50.3	76.8	70.4	61.8	1.4	8.5	K	2.3	302	356	#16	0.57				
1	1739	140	68.3	63.7	55.4	75.6	68.8	59.5	1.8	11.5	L	3.0	308	371	#16	0.57				
1.5	1737	140	72.3	68.5	61.1	76.7	69.8	58.9	2.5	15.4	K	4.5	268	332	#16	0.57	See Power Cable Size Chart			
2	1744	140	74.9	72.7	66.6	75.7	67.4	55.2	3.3	19.8	J	6.0	267	319	#12	0.65			#18	0.45
3	1733	140	77.7	76.2	71.0	79.9	73.1	61.6	4.5	26.8	J	9.0	199	288	#12	0.65			#18	0.45
5	1733	140	80.6	79.4	74.6	81.1	74.7	63.6	7.1	45.1	J	15.0	244	301	#12	0.65			#18	0.45
7.5	1737	180	85.9	87.4	87.0	83.7	78.0	67.1	9.8	64.3	H	22.7	232	310					#14	0.59
10	1735	180	84.0	86.7	86.1	80.6	73.3	60.4	13.8	84.0	H	30.3	238	313					#14	0.59
15	1747	210	86.7	88.6	88.6	81.4	76.4	66.1	19.9	104.8	F	45.1	192	239					#14	0.59
20	1741	210	86.4	88.9	89.6	82.4	78.6	69.6	26.3	131.1	F	60.3	183	223					#14	0.59
25	1761	250	88.8	90.3	90.2	83.8	80.6	72.2	31.4	172.1	F	74.6	192	236					#14	0.59
30	1765	250	90.2	91.6	91.3	85.2	82.3	74.4	37.0	218.0	G	89.4	210	263					#14	0.59
40	1760	250	89.5	91.0	91.0	84.8	81.2	72.3	49.0	298.0	G	119.3	212	265					#14	0.59
50	1771	320	89.3	89.4	87.6	82.1	77.6	67.7	64.0	345.0	F	148.3	175	252					#14	0.59
60	1767	320	90.3	90.9	90.0	87.9	86.8	82.1	71.0	378.0	F	178.3	167	229					#14	0.59
75	1770	320	93.0	93.7	93.3	87.8	85.8	79.7	86.0	560.0	G	222.2	208	266					#14	0.59
100	1785	360	92.4	92.6	91.0	86.9	85.2	79.5	117.0	777.2	G	294.4	197	238					#14	0.59
125	1782	360	93.2	93.2	92.0	86.9	85.4	80.1	145.0	901.0	G	368.5	178	263					#14	0.59
150	1782	360	93.6	93.8	92.8	88.5	87.2	83.0	169.0	1108.0	G	442.1	186	268					#14	0.59
200	1780	L360	94.6	95.1	94.8	88.1	88.7	86.8	225.0	1297.0	F	590.0	165	234					#14	0.59

## YCC DRY-PIT SUBMERSIBLE MOTOR DATA – 4 POLE

H.P.	Full Load RPM	Frame Size	Nominal Eff % @ *			Nominal Power Factor % @			Amps @ 460V		KVA Code Letter	Full Load Torque (Ft Lbs)	% Full Load Torque		S.F. @ 40° C	Power Cable	
			Full Load	3/4 Load	1/2 Load	Full Load	3/4 Load	1/2 Load	Full Load	Locked Rotor			Locked Rotor	Break-down		AWG Size	O.D. ** (in.)
0.75	1765	140	62.0	56.0	42.0	59.0	54.0	42.0	2.0	15.4	K	2.3	524	650	1.00	16	0.570+/-0.030
1	1770	140	66.0	60.0	46.0	56.0	49.0	37.0	2.6	19.8	J	3.0	534	638	1.00	16	0.570+/-0.030
1.5	1765	140	72.0	65.0	55.0	62.0	53.0	42.0	3.3	26.8	J	4.5	398	576	1.00	12	0.650+/-0.030
2.0	1775	140	72.0	68.0	60.0	56.0	51.0	41.0	4.7	45.1	J	6.0	610	753	1.00	12	0.650+/-0.030
3.0	1725	140	80.0	79.0	75.0	88.0	84.0	77.0	4.2	21.0	F	9.0	177	264	1.00	16	0.570+/-0.030
5.0	1785	180	87.0	85.0	80.0	54.0	45.0	33.0	9.1	84.0	H	20.0	238	313	1.00	See Power Cable Size Chart	
	1770	210CLC	80.0	77.9	72.5	83.5	81.1	75.0	7.0	43.6	H	14.8	230	290	1.15		
7.5	1759	210CLC	76.0	73.7	67.9	84.7	82.9	78.6	10.9	60.2	H	22.2	216	263	1.15		
10	1771	210CLC	88.9	88.8	86.9	73.9	66.1	53.5	14.2	105.0	K	29.7	291	363	1.15		
15	1747	210CLC	86.7	88.6	88.6	81.4	76.4	66.1	19.9	104.8	F	45.1	192	239	1.15		
20	1741	210CLC	86.4	88.9	89.6	82.4	78.6	69.6	26.3	131.1	F	60.3	183	223	1.15		
25	1761	250CLC	88.8	90.3	90.2	83.8	80.6	72.2	31.4	172.1	F	74.6	192	236	1.15		
30	1765	250CLC	90.2	91.6	91.3	85.2	82.3	74.4	37.0	218.0	G	89.4	210	263	1.15		
40	1760	250CLC	89.5	91.0	91.0	84.8	81.2	72.3	49.0	298.0	G	119.3	212	265	1.15		
50	1771	320CLC	89.3	89.4	87.6	82.1	77.6	67.7	64.0	345.0	F	148.3	175	252	1.15		
60	1767	320CLC	90.3	90.9	90.0	87.9	86.8	82.1	71.0	378.0	F	178.3	167	229	1.15		
75	1775	320CLC	92.1	91.9	90.9	81.5	77.2	67.3	93.6	580.0	G	221.8	140	240	1.15		
100	1785	360CLC	92.4	92.6	91.0	86.9	85.2	79.5	117.0	777.2	G	294.4	197	238	1.15		
125	1782	360CLC	93.2	93.2	92.0	86.9	85.4	80.1	145.0	901.0	G	368.5	178	263	1.15		
150	1782	360CLC	95.0	94.7	93.6	84.0	80.3	71.3	176.0	1250.0	H	442.0	140	240	1.15		

Typical motor data for Submersible 3 phase, 60 hertz, NEMA design B, 40 °C ambient, normal torque motors. Amperes shown for 460 volt connection. If other connections are available, the amperes will vary inversely with rated voltage. All values nominal.

\*Efficiencies include all mechanical losses including mechanical seals.

\*\* Above cable data for standard motors only, with cable length of 30'. Data is applicable through lengths of 100'. 140 frame motors with #16 AWG cord utilize single cable, (8) conductor, with power and control leads. Control cables must be run in a separate conduit. Not certified for construction. Cable size and dimensions may vary. Confirm with factory before final design or construction.

## YCC STANDARD SUBMERSIBLE MOTOR DATA – 6 POLE

H.P.	Full Load RPM	Frame Size	Nominal Eff % @ *			Nominal Power Factor % @			Amps @ 460V		KVA Code Letter	Full Load Torque (Ft Lbs)	% Full Load Torque		Power Cable		Control Cable	
			Full Load	3/4 Load	1/2 Load	Full Load	3/4 Load	1/2 Load	Full Load	Locked Rotor			Locked Rotor	Break-down	AWG Size	O.D. ** (in.)	AWG Size	O.D. ** (in.)
0.5	1174	140	57.1	50.6	41.0	41	36	30	2	10.3	S	2.25	528	630	#16	0.57	Not Applicable - Single Cable Used	
0.75	1163	140	65.0	59.6	50.6	51	44	36	2.2	10.3	M	3.38	352	420	#16	0.57		
1	1151	140	69.1	65.0	57.1	59	51	41	2.4	10.3	K	4.50	264	315	#16	0.57		
1.5	1153	140	72.2	68.6	61.3	58	50	40	3.4	14.9	J	6.75	254	312	#12	0.65	#18	0.45
2	1159	140	74.6	71.0	63.7	55	46	36	4.7	21.8	K	9.00	279	345	#12	0.65	#18	0.45
3	1153	140	77.8	75.3	69.3	59	50	39	6.2	27.9	J	13.50	240	300	#12	0.65	#18	0.45
5	1147	180	79.5	81.2	80.0	67.0	58.0	45.4	8.8	35.2	G	22.9	161	228	See Power Cable Size Chart			
7.5	1133	180	79.8	81.9	81.2	73.3	64.6	50.9	12.0	51.1	F	34.8	149	224				
10	1156	210	84.0	85.8	85.4	70.7	63.3	51.0	15.8	75.3	G	45.4	212	237				
15	1158	250	85.8	87.5	87.2	77.6	71.1	58.9	21.1	89.1	E	68.0	150	210				
20	1164	250	87.2	89.0	89.0	80.8	75.8	65.0	26.6	124.6	E	90.3	160	220				
25	1162	250	87.7	89.6	89.8	80.8	76.1	65.8	33.0	152.8	E	113.0	162	217				
30	1173	320	87.3	87.8	86.3	81.5	77.4	68.2	39.5	211.0	G	134.3	171	231				
40	1175	320	88.7	88.7	83.9	80.9	73.2	50.3	293.7	G	178.8	186	238					
50	1175	320	89.5	90.6	90.2	85.2	82.8	76.3	61.0	410.3	H	223.2	217	243				
60	1176	320	89.3	90.0	89.2	79.5	74.3	63.7	79.2	489.1	H	267.9	216	263				
75	1178	360	90.7	91.2	90.3	83.8	79.9	70.9	92.0	570.0	G	334.5	146	291				
100	1173	360	90.6	91.7	91.3	84.8	81.7	73.7	122.0	681.0	F	447.6	133	260				
125	1175	360	91.2	92.3	92.1	85.0	81.8	73.6	151.0	913.0	G	558.8	147	280				
150	1175	L360	92.9	94.4	95.1	86.0	83.4	76.2	175.7	1059.0	G	670.7	146	275				

## YCC DRY-PIT SUBMERSIBLE MOTOR DATA – 6 POLE

H.P.	Full Load RPM	Frame Size	Nominal Eff % @ *			Nominal Power Factor % @			Amps @ 460V		KVA Code Letter	Full Load Torque (Ft-Lbs)	% Full Load Torque		S.F. @ 40° C Amb.	Power Cable	
			Full Load	3/4 Load	1/2 Load	Full Load	3/4 Load	1/2 Load	Full Load	Locked Rotor			Locked Rotor	Break-down		AWG Size	O.D. ** (in.)
0.75	1175	180	54.9	48.1	39.9	61.3	56.9	49.5	2.0	15.8	S	3.4	495	591	1.00	See Power Cable Size Chart	
1	1170	180	60.9	54.9	45.2	68.0	61.3	55.1	2.4	15.8	P	4.5	370	441	1.15		
1.5	1160	180	64.8	62.2	54.9	74.9	70.1	61.3	2.7	15.8	L	6.8	244	292	1.00		
2	1165	180	72.2	70.2	64.9	71.9	66.3	55.1	3.5	25.2	L	9.0	256	314	1.00		
3	1165	210CLC	87.5	86.6	82.7	61.5	53.2	41.6	5.2	43.3	N	13.3	371	466	1.15		
5	1145	210CLC	87.6	86.9	84.0	64.4	56.5	44.4	8.3	53.0	K	22.3	291	353	1.15		
7.5	1140	210CLC	86.5	87.7	86.9	73.2	67.4	56.5	11.1	53.1	G	33.9	192	232	1.15		
10	1156	210CLC	84.0	85.8	85.4	70.7	63.3	51.0	15.8	75.3	G	45.4	212	237	1.15		
15	1158	250CLC	85.8	87.5	87.2	77.6	71.1	58.9	21.1	89.1	E	68.0	150	210	1.15		
20	1164	250CLC	87.2	89.0	89.0	80.8	75.8	65.0	26.6	124.6	E	90.3	160	220	1.15		
25	1162	250CLC	87.7	89.6	89.8	80.8	76.1	65.8	33.0	152.8	E	113.0	162	217	1.15		
30	1173	320CLC	87.3	87.8	86.3	81.5	77.4	68.2	39.5	211.0	G	134.3	171	231	1.15		
40	1175	320CLC	88.7	89.6	88.7	83.9	80.9	73.2	50.3	293.7	G	178.8	186	238	1.15		
50	1186	320CLC	94.2	94.4	93.9	80.6	77.8	70.0	61.7	345.0	F	221.0	154	230	1.15		
60	1177	320CLC	91.2	91.2	90.9	80.7	76.7	66.9	76.3	466.0	G	238.1	150	275	1.15		
75	1178	360CLC	90.7	91.2	90.3	83.8	79.9	70.9	92.0	570.0	G	334.5	146	291	1.15		
100	1173	360CLC	90.6	91.7	91.3	84.8	81.7	73.7	122.0	681.0	F	447.6	133	260	1.15		
125	1177	360CLC	90.6	90.7	90.4	84.5	81.5	73.0	152.9	960.0	G	557.6	140	275	1.15		

Typical motor data for Submersible 3 phase, 60 hertz, NEMA design B, 40 °C ambient, normal torque motors. Amperes shown for 460 volt connection. If other connections are available, the amperes will vary inversely with rated voltage. All values nominal.

\*Efficiencies include all mechanical losses including mechanical seals.

\*\* Above cable data for standard motors only, with cable length of 30'. Data is applicable through lengths of 100'. 140 frame motors with #16 AWG cord utilize single cable, (8) conductor, with power and control leads. Control cables must be run in a separate conduit. Not certified for construction. Cable size and dimensions may vary. Confirm with factory before final design or construction.

## YCC STANDARD SUBMERSIBLE MOTOR DATA – 8 POLE

H.P.	Full Load RPM	Frame Size	Nominal Eff % @ *			Nominal Power Factor % @			Amps @ 460V		KVA Code Letter	Full Load Torque (Ft-Lbs)	% Full Load Torque		Power Cable		Control Cable	
			Full Load	3/4 Load	1/2 Load	Full Load	3/4 Load	1/2 Load	Full Load	Locked Rotor			Locked Rotor	Break-down	AWG Size	O.D. ** (in.)	AWG Size	O.D. ** (in.)
0.5	864	140	58.7	53.2	44.1	51.0	44.0	36.0	1.6	5.6	K	3.0	265	320	#16	0.57	Not Applicable - Single Cable Used	
0.75	862	140	64.1	59.3	50.7	52.0	45.0	36.0	2.1	7.6	K	4.5	239	295	#16	0.57		
1	863	140	68.4	64.2	56.2	53.0	45.0	36.0	2.6	9.7	J	6.0	229	288	#16	0.57		
1.5	861	140	72.1	68.6	61.3	54.0	45.0	36.0	3.6	13.8	J	9.0	221	278	#12	0.65	#18	0.45
2	862	140	74.8	71.6	64.7	52.0	44.0	34.0	4.8	18.5	J	12.0	226	285	#12	0.65	#18	0.45
3	846	180	73.1	73.2	69.0	59.4	49.9	38.1	6.5	25.4	H	18.6	213	269	See Power Cable Size Chart	#14	0.59	
5	865	210	80.0	78.9	74.5	60.6	52.2	40.9	9.7	47.4	J	30.3	190	311		#14	0.59	
7.5	858	210	82.8	83.8	82.2	65.4	56.9	44.6	13.0	57.2	G	45.9	160	260		#14	0.59	
10	878	250	86.2	86.6	85.0	68.1	60.0	47.9	15.9	72.5	G	59.8	177	244		#14	0.59	
15	870	250	85.6	87.4	87.0	72.3	66.3	54.6	22.7	85.2	E	90.5	137	191		#14	0.59	
20	882	320	89.0	89.6	88.5	77.8	74.2	65.8	27.1	136.9	F	119.0	156	212		#14	0.59	
25	880	320	88.2	89.4	88.8	77.6	74.0	65.2	34.0	162.0	F	149.1	150	199		#14	0.59	
30	880	320	87.5	89.6	89.2	77.3	73.3	64.1	42.0	216.0	G	179.2	163	209		#14	0.59	
40	878	320	87.8	89.1	88.6	76.6	72.7	63.4	55.7	263.7	F	239.2	164	200		#14	0.59	
50	881	360	88.2	89.4	88.8	76.9	70.9	59.2	69.0	344.0	F	298.2	122	247		#14	0.59	
60	881	360	89.1	90.3	89.9	77.1	71.2	59.6	82.0	425.0	G	357.7	129	257		#14	0.59	
75	881	360	89.1	90.3	89.9	75.8	69.0	56.7	104.0	543.0	G	447.3	137	262		#14	0.59	
100	881	360	89.9	91.0	90.7	75.9	69.1	56.6	137.0	745.0	G	596.2	144	273		#14	0.59	
125	880	360	90.2	91.7	91.8	77.9	71.9	60.0	167.0	913.0	G	745.9	146	267		#14	0.59	

## YCC DRY-PIT SUBMERSIBLE MOTOR DATA – 8 POLE *Refer to Factory*

Typical motor data for Submersible 3 phase, 60 hertz, NEMA design B, 40 °C ambient, normal torque motors. Amperes shown for 460 volt connection. If other connections are available, the amperes will vary inversely with rated voltage. All values nominal.

\*Efficiencies include all mechanical losses including mechanical seals.

\*\* Above cable data for standard motors only, with cable length of 30'. Data is applicable through lengths of 100'. 140 frame motors with #16 AWG cord utilize single cable, (8) conductor, with power and control leads. Control cables must be run in a separate conduit. Not certified for construction. Cable size and dimensions may vary. Confirm with factory before final design or construction.



## YCC SUBMERSIBLE MOTOR DATA POWER CABLE SIZING CHART

H.P.	Full Load RPM	Frame Size	Power Cable(s)														
			200V			230V			380V			460V			575V		
			FLA	AWG Size	O.D. (in.)	FLA	AWG Size	O.D. (in.)	FLA	AWG Size	O.D. (in.)	FLA	AWG Size	O.D. (in.)	FLA	AWG Size	O.D. (in.)
7.5	1737	180	22.5	12	0.71	19.6	12	0.65	19.60	12	0.65	19.6	12	0.65	16.0	16	0.42
10	1735	180	31.7	8	0.99	27.6	10	0.71	27.60	10	0.71	27.6	10	0.71	22.6	16	0.42
15	1747	210	45.8	8	0.99	39.8	8	0.99	39.80	8	0.99	39.8	8	0.99	32.5	14	0.58
20	1741	210	60.5	6	1.10	52.6	6	1.10	52.60	6	1.10	52.6	6	1.10	43.0	12	0.65
25	1761	250	72.2	4	1.25	62.8	6	1.10	62.80	6	1.10	62.8	6	1.10	51.3	10	0.71
30	1765	250	85.1	4	1.25	74.0	4	1.25	74.00	4	1.25	74.0	4	1.25	60.5	8	0.99
40	1760	250	112.7	2	1.45	98.0	2	1.25	59.34	6	1.10	49.0	8	0.99	40.1	8	0.99
50	1771	320										64.0	6	1.10	52.3	6	1.10
60	1767	320										71.0	4	1.25	58.0	6	1.10
75	1770	320										86.0	4	1.25	70.3	4	1.25
100	1785	360										117.0	2	1.45	95.6	2	1.45
125	1782	360										145.0	2 x #4	1.25	118.5	2	1.45
150	1782	360										169.0	2 x #4	1.25	138.1	1	1.68
200	1780	L360										225.0	2 x #2	1.45	183.9	2 x #2	1.45
Please Refer to Factory																	
5	1147	180	20.2	12	0.65	17.6	14	0.58	17.60	14	0.58	17.6	14	0.58	14.4	16	0.42
7.5	1133	180	27.6	10	0.71	24.0	12	0.65	24.00	12	0.65	24.0	12	0.65	19.6	16	0.42
10	1156	210	36.3	8	0.99	31.6	8	0.99	31.60	8	0.99	31.6	8	0.99	25.8	14	0.58
15	1158	250	48.5	8	0.99	42.2	8	0.99	42.20	8	0.99	42.2	8	0.99	34.5	14	0.58
20	1164	250	61.2	6	1.10	53.2	6	1.10	53.20	6	1.10	53.2	6	1.10	43.5	12	0.65
25	1162	250	75.9	4	1.25	66.0	6	1.10	66.00	6	1.10	66.0	6	1.10	53.9	10	0.71
30	1173	320	90.9	4	1.25	79.0	4	1.25	79.00	4	1.25	79.0	4	1.25	64.6	8	0.99
40	1175	320	115.7	2	1.45	100.6	2	1.45	60.91	6	1.10	50.3	8	0.99	41.1	8	0.99
50	1175	320										61.0	6	1.10	49.9	8	0.99
60	1176	320										79.2	4	1.25	64.7	6	1.10
75	1178	360										92.0	2	1.45	75.2	4	1.25
100	1173	360										122.0	2	1.45	99.7	2	1.45
125	1175	360										151.0	2 x #4	1.25	123.4	1	1.68
150	1175	L360										175.7	2 x #4	1.25	143.6	2 x #4	1.25
Please Refer to Factory																	
3	846	180	15.0	14	0.65	13.0	14	0.58	13.0	14	0.58	13.0	14	0.58	10.6	16	0.42
5	865	210	22.3	12	0.65	19.4	12	0.65	19.4	12	0.65	19.4	12	0.65	15.9	16	0.42
7.5	858	210	29.9	8	0.99	26.0	10	0.71	26.0	10	0.71	26.0	10	0.71	21.3	16	0.42
10	878	250	36.6	8	0.99	31.8	8	0.99	31.8	8	0.99	31.8	8	0.99	26.0	14	0.58
15	870	250	52.2	6	1.10	45.4	8	0.99	45.4	8	0.99	45.4	8	0.99	37.1	12	0.65
20	882	320	62.3	6	1.10	54.2	6	1.10	54.2	6	1.10	54.2	6	1.10	44.3	12	0.65
25	880	320	78.2	4	1.25	68.0	6	1.10	68.0	6	1.10	68.0	6	1.10	55.6	10	0.71
30	880	320	96.6	2	1.45	84.0	4	1.25	84.0	4	1.25	84.0	4	1.25	68.7	8	0.99
40	878	320	128.1	1	1.68	111.4	2	1.45	67.45	6	1.10	55.7	6	1.10	45.5	8	0.99
50	881	360										69.0	6	1.10	56.4	6	1.10
60	881	360										82.0	4	1.25	67.0	6	1.10
75	881	360										104.0	2	1.45	85.0	4	1.25
100	881	360										137.0	1	1.68	112.0	2	1.45
125	880	360										167.0	2 x #4	1.25	136.5	1	1.68

### NOTES / CLARIFICATIONS:

- Sizing is applicable for lengths through 75 feet. For other lengths, please refer to factory.
- The designation "2 x" preceding the AWG number indicates that there are two (2) power cables of the listed size. Cable O.D. values are nominal and subject to variation.
- Data is subject to change and is not certified for construction purposes. Please verify sizes with factory prior to construction or sizing of terminals and conduits.

### RECOMMENDED CABLE TYPES & MANUFACTURERS

MANUFACTURER	CABLE	TYPE	MFR. CAT. NO.	YCC P/N	NOM. OD
COLEMAN	1x4	PPE	30265	C10-31-19	1.6800
	2x4	PPE	30264	C10-31-30	1.4800
	4x4	PPE	30262	C10-31-29	1.2700
	6x4	PPE	30261	C10-31-28	1.1000
	8x4	PPE	30260	C10-31-27	0.9900
	10x4	SEOOW	22429	C10-31-33	0.7100
	12x4	SEOOW	22428	C10-31-34	0.6450
	14x4 (power)	SEOOW	22427	C10-31-35	0.5750
	14x4 (control)	SEOOW	24236	C10-31-5	0.5750
	16x4	SEOOW	22426	C10-31-32	0.4150
GENERAL CABLE	1x4	W	81374.99.01	C10-31-19	1.6800
	2x4	W	81664.99.01	C10-31-30	1.4350
	4x4	W	81644.99.01	C10-31-29	1.2200
	6x4	W	81624.99.01	C10-31-28	1.0900
	8x4	W	81314.99.01	C10-31-27	0.9850
	10x4	SOOW	02727	C10-31-33	0.7150
	12x4	SOOW	02726	C10-31-34	0.6500
	14x4	SOOW	02768	C10-31-35	0.5750
PRIORITY WIRE & CABLE	1x4	W	02766	C10-31-32	0.4200
	1x4	W	P26N2	C10-31-19	1.6800

**NOTE - The above commercial cable types have been tested and approved by YCC. Use of other cable types or sizes is not recommended and may void the motor warranty. YCC assumes no liability for motor failure or other damage that might result from the use of cable types or sizes other than those shown.**

# MODU-CAB® REPLACEMENT PARTS & REBUILD KITS

**Complete MODU-CAB® Assembly:** Includes complete replacement cap and cable assembly, including 30' or 50' electrical cables. (Please refer to factory for other lengths.)

**Sensor & Power Modules:** Individual cable module assemblies, with connector body and 30' or 50' electrical cable. Includes o-ring for mounting the module to the cap. (Please refer to factory for other lengths.)

**Rebuild Kits:** Include the necessary grommets, washers, o-rings and other components for rebuilding a power or sensor module. *Rebuild Kits do not include electrical cable. Please refer to the chart "RECOMMENDED CABLE TYPES & MANUFACTURERS" for approved cable types.*

**Please refer to factory for ratings / voltages not listed.**

HP	Motor Speed	Voltage	Frame	Complete MODU-CAB® Assemblies		Sensor Modules		Power Modules		Rebuild Kits		AWG Size (Power)
				30'	50'	30'	50'	30'	50'	Sensor	Power	
3	8 POLE	200/230	180/210	A-112346-003	A-112346-007	A-112156-013	A-112156-027	A-112156-043	A-112156-044	A-112453-01	A-112453-01	14
		380/460/575	180/210	A-112346-004	A-112346-008	A-112156-013	A-112156-027	A-112156-014	A-112156-028	A-112453-01	A-112453-02	16
5	6 POLE	200	180/210	A-112346-002	A-112346-006	A-112156-013	A-112156-027	A-112156-014	A-112156-028	A-112453-01	A-112453-02	12
		230	180/210	A-112346-003	A-112346-007	A-112156-013	A-112156-027	A-112156-043	A-112156-044	A-112453-01	A-112453-01	14
	380/460/575	180/210	A-112346-004	A-112346-008	A-112156-013	A-112156-027	A-112156-014	A-112156-028	A-112453-01	A-112453-02	16	
	8 POLE	200/230	180/210	A-112346-002	A-112346-006	A-112156-013	A-112156-027	A-112156-014	A-112156-028	A-112453-01	A-112453-02	12
		380/460/575	180/210	A-112346-004	A-112346-008	A-112156-013	A-112156-027	A-112156-014	A-112156-028	A-112453-01	A-112453-02	16
7.5	4 POLE	200/230	180/210	A-112346-002	A-112346-006	A-112156-013	A-112156-027	A-112156-014	A-112156-028	A-112453-01	A-112453-02	12
		380/460/575	180/210	A-112346-004	A-112346-008	A-112156-013	A-112156-027	A-112156-014	A-112156-028	A-112453-01	A-112453-02	16
	6 POLE	200	180/210	A-112346-001	A-112346-005	A-112156-013	A-112156-027	A-112156-010	A-112156-024	A-112453-01	A-112453-03	10
		230	180/210	A-112346-002	A-112346-006	A-112156-013	A-112156-027	A-112156-014	A-112156-028	A-112453-01	A-112453-02	12
		380	180/210	A-112346-003	A-112346-007	A-112156-013	A-112156-027	A-112156-043	A-112156-044	A-112453-01	A-112453-01	14
		460/575	180/210	A-112346-004	A-112346-008	A-112156-013	A-112156-027	A-112156-014	A-112156-028	A-112453-01	A-112453-02	16
	8 POLE	200	180/210	A-112208-002	A-112208-004	A-112156-013	A-112156-027	A-112156-009	A-112156-023	A-112453-01	A-112453-04	8
		230	180/210	A-112346-001	A-112346-005	A-112156-013	A-112156-027	A-112156-010	A-112156-024	A-112453-01	A-112453-03	10
	380/460	180/210	A-112346-003	A-112346-007	A-112156-013	A-112156-027	A-112156-043	A-112156-044	A-112453-01	A-112453-01	14	
	575	180/210	A-112346-004	A-112346-008	A-112156-013	A-112156-027	A-112156-014	A-112156-028	A-112453-01	A-112453-02	16	
10	4 POLE	200	180/210	A-112208-002	A-112208-004	A-112156-013	A-112156-027	A-112156-009	A-112156-023	A-112453-01	A-112453-04	8
		230	180/210	A-112346-001	A-112346-005	A-112156-013	A-112156-027	A-112156-010	A-112156-024	A-112453-01	A-112453-03	10
		380/460	180/210	A-112365-007	A-112365-016	A-112156-013	A-112156-027	A-112156-043	A-112156-044	A-112453-01	A-112453-01	14
		575	180/210	A-112346-004	A-112346-008	A-112156-013	A-112156-027	A-112156-014	A-112156-028	A-112453-01	A-112453-02	16
	6 POLE	380	180/210	A-112346-002	A-112346-006	A-112156-013	A-112156-027	A-112156-014	A-112156-028	A-112453-01	A-112453-02	12
		200/230	180/210	A-112208-002	A-112208-004	A-112156-013	A-112156-027	A-112156-009	A-112156-023	A-112453-01	A-112453-04	8
		460/575	180/210	A-112346-003	A-112346-007	A-112156-013	A-112156-027	A-112156-043	A-112156-044	A-112453-01	A-112453-01	14
		8 POLE	200/230	250/360	A-112365-004	A-112365-013	A-112156-013	A-112156-027	A-112156-009	A-112156-023	A-112453-01	A-112453-04
	380	250/360	A-112365-006	A-112365-015	A-112156-013	A-112156-027	A-112156-011	A-112156-025	A-112453-01	A-112453-06	12	
	460/575	250/360	A-112365-007	A-112365-016	A-112156-013	A-112156-027	A-112156-043	A-112156-044	A-112453-01	A-112453-01	14	
15	4 POLE	200/230	180/210	A-112208-002	A-112208-004	A-112156-013	A-112156-027	A-112156-009	A-112156-023	A-112453-01	A-112453-04	8
		380	180/210	A-112346-001	A-112346-005	A-112156-013	A-112156-027	A-112156-010	A-112156-024	A-112453-01	A-112453-03	10
		460	180/210	A-112346-002	A-112346-006	A-112156-013	A-112156-027	A-112156-014	A-112156-028	A-112453-01	A-112453-02	12
		575	180/210	A-112346-003	A-112346-007	A-112156-013	A-112156-027	A-112156-043	A-112156-044	A-112453-01	A-112453-01	14
	6 POLE	200/230	250/360	A-112365-004	A-112365-013	A-112156-013	A-112156-027	A-112156-009	A-112156-023	A-112453-01	A-112453-04	8
		380	250/360	A-112346-001	A-112346-005	A-112156-013	A-112156-027	A-112156-010	A-112156-024	A-112453-01	A-112453-03	10
		460	250/360	A-112365-006	A-112365-015	A-112156-013	A-112156-027	A-112156-011	A-112156-025	A-112453-01	A-112453-06	12
		575	250/360	A-112365-007	A-112365-016	A-112156-013	A-112156-027	A-112156-043	A-112156-044	A-112453-01	A-112453-01	14
8 POLE	200	250/360	A-112365-004	A-112365-012	A-112156-013	A-112156-027	A-112156-008	A-112156-022	A-112453-01	A-112453-05	6	
	230	250/360	A-112365-003	A-112365-013	A-112156-013	A-112156-027	A-112156-009	A-112156-023	A-112453-01	A-112453-04	8	
	380	250/360	A-112365-005	A-112365-014	A-112156-013	A-112156-027	A-112156-010	A-112156-024	A-112453-01	A-112453-03	10	
	460/575	250/360	A-112365-006	A-112365-015	A-112156-013	A-112156-027	A-112156-011	A-112156-025	A-112453-01	A-112453-06	12	
20	4 POLE	200/230	180/210	A-112208-001	A-112208-003	A-112156-013	A-112156-027	A-112156-008	A-112156-022	A-112453-01	A-112453-05	6
		380	180/210	A-112208-002	A-112208-004	A-112156-013	A-112156-027	A-112156-009	A-112156-023	A-112453-01	A-112453-04	8
		460	180/210	A-112346-001	A-112346-005	A-112156-013	A-112156-027	A-112156-010	A-112156-024	A-112453-01	A-112453-03	10
		575	180/210	A-112346-002	A-112346-006	A-112156-013	A-112156-027	A-112156-014	A-112156-028	A-112453-01	A-112453-02	12
	6 POLE	200/230	250/360	A-112365-003	A-112365-012	A-112156-013	A-112156-027	A-112156-008	A-112156-022	A-112453-01	A-112453-05	6
		380	250/360	A-112365-004	A-112365-013	A-112156-013	A-112156-027	A-112156-009	A-112156-023	A-112453-01	A-112453-04	8
		460	250/360	A-112365-005	A-112365-014	A-112156-013	A-112156-027	A-112156-010	A-112156-024	A-112453-01	A-112453-03	10
		575	250/360	A-112365-006	A-112365-015	A-112156-013	A-112156-027	A-112156-011	A-112156-025	A-112453-01	A-112453-06	12
8 POLE	200/230	250/360	A-112365-004	A-112365-012	A-112156-013	A-112156-027	A-112156-008	A-112156-022	A-112453-01	A-112453-05	6	
	380	250/360	A-112365-003	A-112365-013	A-112156-013	A-112156-027	A-112156-009	A-112156-023	A-112453-01	A-112453-04	8	
	460	250/360	A-112365-005	A-112365-014	A-112156-013	A-112156-027	A-112156-010	A-112156-024	A-112453-01	A-112453-03	10	
	575	250/360	A-112365-006	A-112365-015	A-112156-013	A-112156-027	A-112156-011	A-112156-025	A-112453-01	A-112453-06	12	

(CONTINUED ON FOLLOWING PAGE)



# MODU-CAB® CABLE CONNECTOR REBUILD PROCEDURES

## Disassembly

To repair or rebuild a cable connector, the entire MODU-CAB® cap and cable assembly must be removed from the motor and all leads must be disconnected from both the terminal assembly and the power connection at the supply. Please refer to Cable Connector Assembly drawing (page 30) for illustration of referenced items.

- 1) Remove the cable connector assembly (Item 9a, 9b or 9c) from the MODU-CAB® cap and cable assembly by removing the fasteners (Item 9h) holding the cable connector body (Item 9g or 9h) to the cap.
- 2) Only the connector body (Item 9g or 9h) is to be reused and all other parts removed from the assembly are to be discarded. All components to make the repair are included in the repair kit except the electrical cable.
- 3) If any epoxy is present on the retaining ring (Item 9i), sleeve (Item 9k) or connector body (Item 9g or 9h) it must first be carefully scraped or chipped from the parts before removal. The retaining ring (item 9i) is to be removed from the connector body (Item 9g or 9h) with an appropriate tool, then the sleeve (Item 9k) can be forced out of the connector body (Item 9g or 9h). All washers (Item 9o) must be removed from the connector body (Item 9g or 9h) before continuing with reassembly.

## Assembly

- 1) Cut new cable (Item 9e or 9f) to the desired length. Do not exceed original cable length without consulting factory.
- 2) Thoroughly clean the connector body (Item 9g or 9h), washers (Item 9o) and sleeve (Item 9k) to remove all dirt, oil and epoxy residue. These parts must be completely clean and dry before assembly.
- 3) For specific assembly and specific cable size, strip jackets and if necessary, cut wires by dimensions shown on the table on Page 30. Strip insulation from each wire by dimensions shown on Page 30.
- 4) Clean inner surface of grommet (Item 9p) and first 24 inches of cable jacket (cable end in contact with connector body) with alcohol to remove oil and dirt.
- 5) Slide connector body (Item 9g or 9h), washer (Item 9o) grommet (Item 9p), second washer (Item 9o) and sleeve (Item 9k) over the cable jacket.
- 6) For specific assembly and specific cable size, strip jackets and if necessary, cut wires by dimensions shown on the table on Page 30. Install cable tie (Item 9l). If applicable, insert nylon screw (Item 9m). For assemblies with nylon screw, install second cable tie (Item 9n) as close to the end of nylon screw head as possible. For assemblies without nylon screw, install second cable tie (Item 9n) as close to the end of jacket as possible. All cable ties shall be tied by using cable tie tensioner with tying force set to 50 lb. or 120 lb., depending on the cable tie size used.
- 7) Place and hold connector body (Item 9g or 9h) in holding fixture (e.g. vise) with the side to be inserted cap up.
- 8) Insert washers (Item 9o), grommet (Item 9p) and sleeve (Item 9k) into the connector body. Pull down cable till cable rests on the washer.
- 9) Place retaining ring (Item 9i) and
  - 9.1.- Mounting tool (reference Drawings M-112260 & M-112261) into the connector body. Place 3/8-16 screws and nuts.  
or
  - 9.2.- Retaining ring pusher (reference Drawings M-112349 & M-112350) into the connector body. Use arbor press. Apply pressure on the pusher till the pusher reaches the stop. Remove pusher.

Check if the retaining ring is sitting completely in the groove. If not, repeat steps above until the

retaining ring is sitting completely in the groove.

- 10) Mix epoxy potting compound (resin) with catalyst (hardener) (Item 9j) per instructions.
- 11) Pour epoxy (Item 9j) to the level shown on Page 30. Do not allow epoxy to reach the retaining ring.
- 12) Allow epoxy to cure and dry for 24 hours.
- 13) Test cable connector assembly for short circuits and continuity.

# CABLE CONNECTOR ASSEMBLY

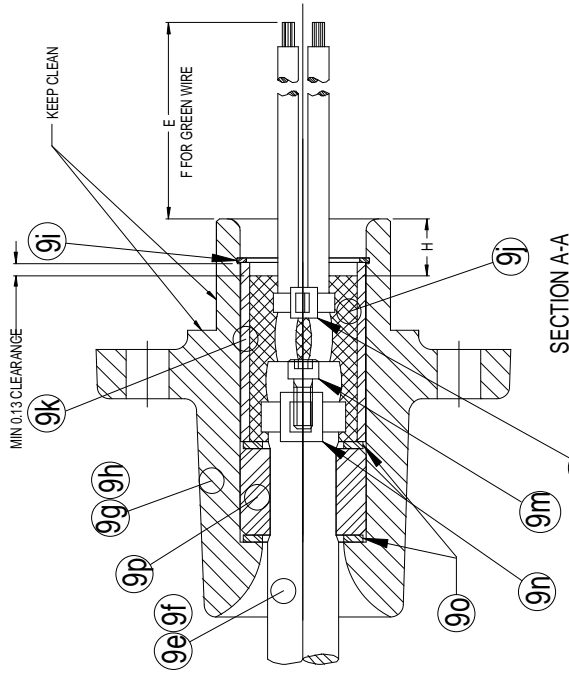

SECTION A-A

(50 LB FOR CABLES FROM 10x4 TO 16x4, 120 LB FOR CABLES FROM 1x4 TO 8x4)

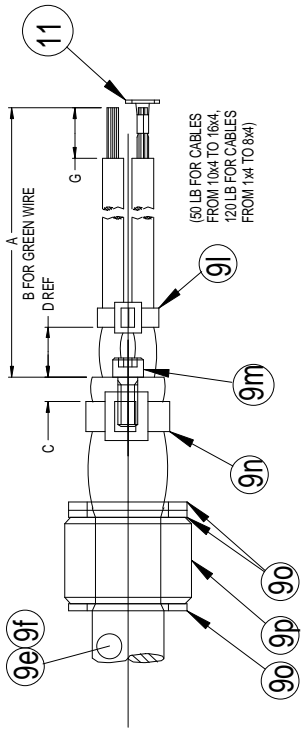
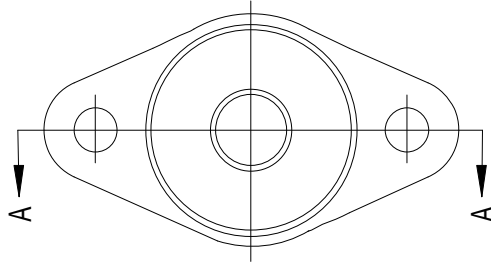

CABLE PREPARATION (NTS)

NOTES:  
 1. ALL DIMENSIONS ARE IN INCHES  
 2. FOR DASH NO. 16, DIMENSIONS A & E SHALL BE DETERMINED DURING ASSEMBLY & REPORTED TO THE ENG. DEPT.

DASH NO.	DESCRIPTION	A	B	C	D	E	F	G	H
1	CABLE CONNECTOR ASSY FOR SPECIAL CABLE 1x4 WITH TERMINAL	19.50	15.00	0.50	0.25	17.00	12.50	0.63	0.88
2	CABLE CONNECTOR ASSY FOR CABLE 1x4 WITH TERMINAL	6.00	8.50	0.50	0.25	6.00	10.50	0.63	0.88
3	STD CABLE CONNECTOR ASSY FOR CABLE 1x4	6.75	6.75	0.50	0.25	6.00	6.00	0.63	0.88
4	CABLE CONNECTOR ASSY FOR CABLE 2x4 WITH TERMINAL	8.50	13.00	0.50	1.00	6.00	10.50	0.63	0.88
5	STD CABLE CONNECTOR ASSY FOR CABLE 2x4	8.50	8.50	0.50	1.00	6.00	6.00	0.63	0.88
6	CABLE CONNECTOR ASSY FOR CABLE 4x4 WITH TERMINAL	8.50	13.00	0.50	1.00	6.00	10.50	0.63	0.88
7	STD CABLE CONNECTOR ASSY FOR CABLE 4x4	8.50	8.50	0.50	1.00	6.00	6.00	0.63	0.88
8	STD CABLE CONNECTOR ASSY FOR CABLE 6x4	8.50	8.50	0.50	1.00	6.00	6.00	0.63	0.88
9	STD CABLE CONNECTOR ASSY FOR CABLE 8x4	9.44	9.44	0.25	0.50	8.00	8.00	0.38	0.63
10	STD CABLE CONNECTOR ASSY FOR CABLE 10x4	9.44	9.44	0.25	0.50	8.00	8.00	0.38	0.63
11	CABLE CONNECTOR ASSY FOR SPECIAL CABLE 14x4	18.50	18.50	0.25	0.50	17.00	17.00	0.38	0.63
13	STD CABLE CONNECTOR ASSY FOR CABLE 14x4	9.44	9.44	0.25	0.50	8.00	8.00	0.38	0.63
14	STD CABLE CONNECTOR ASSY FOR CABLE 16x4	9.44	9.44	0.25	0.50	8.00	8.00	0.38	0.63
15	STD CABLE CONNECTOR ASSY FOR CABLE 16x8	9.44	9.44	0.25	0.50	8.00	8.00	0.38	0.63
16	CABLE CONNECTOR ASSY FOR SPECIAL CABLE 24x37	SEE NOTE	-	0.25	0.50	SEE NOTE	-	-	0.63

ITEM NO.	PART DESCRIPTION	QTY
9g or 9h	CONNECTOR BODY	1
9e or 9f	CABLE	1
9p	GROMMET	1
9o	WASHER	2
9k	SLEEVE	1
9i	RETAINING RING	1
9j	SEALING COMPOUND	1
9n	CABLE TIE, 120 LB.	1
9m	SHCS, NYLON 6/6	1
9l	CABLE TIE	1
11	RING TERMINAL FOR GROUNDING	1

MOUNTING TOOL – Dwg. A-112260, Rev. C, 1/4/05

