

# 140 FRAME YCC SUBMERSIBLE MOTOR

## INSTALLATION, OPERATION AND MAINTENANCE MANUAL

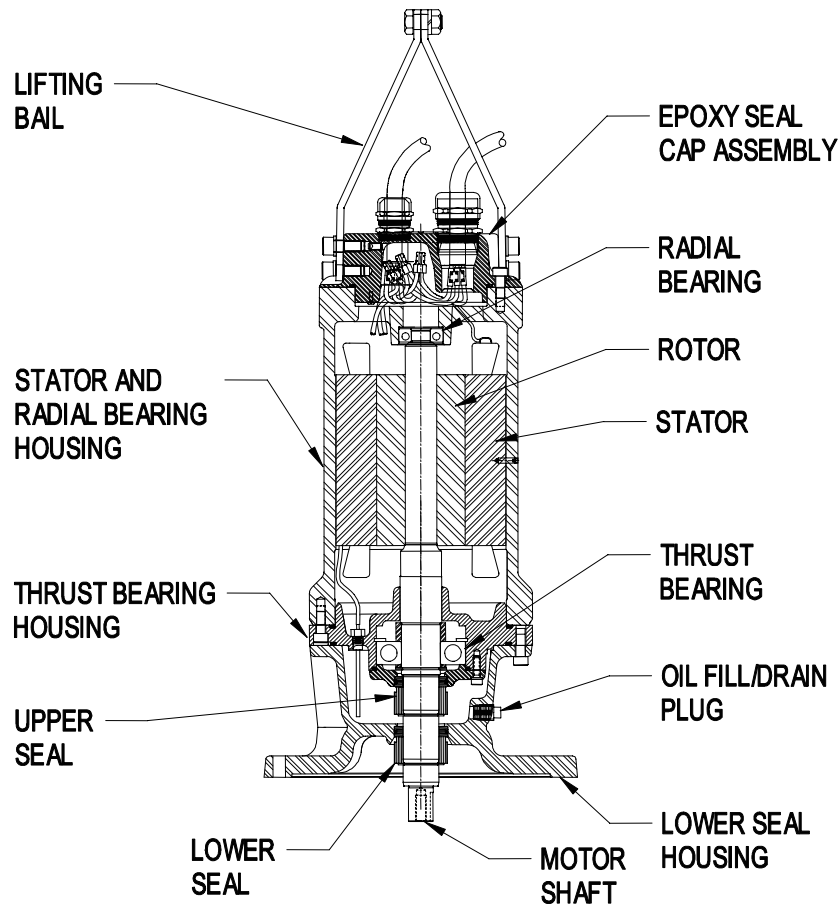

## TYPICAL MOTOR DETAIL YCC 140 FRAME



**3905 ENTERPRISE COURT  
AURORA, IL 60598 USA**

# Table of Contents

	<b>Page</b>
Acceptance of Shipment and Caution Statements	3
General Notes	3
Factory Mutual Approved Motors	4
Long Term Storage Instructions	4
Installation Notes	4
Start-Up	5
Maintenance	5
Thermal Protection System	5
Table 1 - Maximum Current Capacity of Motor Thermostats	6
Moisture Detection System	6
Disassembly Instructions	8
Re-assembly Instructions	9
Table 2 - Recommended Oil Quantity for Seal Chamber	10
Table 3 - Recommended Oil Types	10
Maintenance Data for Mechanical Seals	10
Figure 1 - Typical Wiring Diagram-Thermal Protectors	11
Figure 2 - Typical Wiring Diagram-Moisture Detection	11
Figure 3 - Seal Cap & Motor Wiring Diagram (110257) 3-Phase Single Cable	12
Figure 4 - Seal Cap & Motor Wiring Diagram (110258) 3-Phase Dual Cable	13
Figure 5 - Seal Cap & Motor Wiring Diagram (110256) 1-Phase Dual Voltage	14
Figure 6 - Seal Cap & Motor Wiring Diagram (110269) 1-Phase 230V only	15
Figure 7 - Motor Cross Section, 140 Frame Motor (111676)	16
Figure 8 - Parts List for Figure 7 (111676)	17
**MECHANICAL SEAL ADDENDUM	18
Typical Motor Data	19-21

YCC Mailing Address:  
PO BOX 6620  
AURORA, IL 60598-0620

YCC Shipping Address:  
3905 ENTERPRISE CT  
AURORA, IL 60504

(630) 236-5500 PHONE  
(630) 236-5511 FAX

## ACCEPTANCE OF SHIPMENT

Thoroughly inspect this equipment before accepting shipment from the transportation company. If any of the goods called for in the bill of lading or express receipt are damaged or the quantity is short, do not accept them until the freight or express agent makes an appropriate notation on your freight bill or express receipt. If any concealed loss or damage is discovered later, notify your freight or express agent at once and request him to make an inspection. We will assist you in collecting claims for loss or damage in shipment; however, this willingness on our part does not remove the transportation company's responsibility in reimbursing you for collection of claims or replacement of material. Claims for loss or damage in shipment must not be deducted from the YCC invoice, nor should payment of the YCC invoice be withheld awaiting adjustment of such claims, as the carrier guarantees safe delivery. If considerable damage has been incurred and the situation is urgent, contact the nearest YCC Representative or the factory for assistance. Please keep a written record of all such communications.

## IMPORTANT

**THOROUGHLY READ ALL INSTRUCTIONS BEFORE SERVICING YCC MOTORS.** YCC cannot be responsible for any damage resulting from failure to comply with these instructions. This motor is not to be operated at conditions, nor with liquids other than those stated in the original order acknowledgement or YCC's Typical Specifications without written permission from YCC. Keep this manual handy for ready reference. Extra sets of motor nameplates are furnished for future reference. These should be retained in a safe place. Information shown on the nameplate is required for ordering replacement parts.

## CAUTION

Surface temperature of the motor enclosure may reach temperatures that can cause discomfort or injury to personnel making accidental contact. The user should provide protection against accidental contact with hot surfaces.

## WARNING

MOTOR MAY CONTAIN GAS UNDER PRESSURE DUE TO HIGH TEMPERATURES FROM ABNORMAL OPERATION. DISASSEMBLY MAY CAUSE BODILY INJURY. CARE MUST BE TAKEN IN DISASSEMBLY. CONTACT **YCC** FOR ASSISTANCE.

## GENERAL NOTES

- 1) Motor - YCC Submersible Motors are T.E.N.V., of an explosion-proof, tandem seal design, with an oil chamber separate from the winding area. To insure the integrity of sealing surfaces and explosion-proof fits when servicing these motors, all parts should be handled with utmost care.
- 2) Wound Stators - YCC Submersible Motors have stator insulation systems specifically designed for the temperature and electrical ratings involved. If motor failure is analyzed to encompass a winding failure, it is required that a replacement wound stator be ordered from YCC.
- 3) Epoxy Seal Cap Assembly - The leads have been specially encapsulated to insure integrity of the motor. The cap assembly can be removed from the motor in order to perform normal repairs. Should the lead cap assembly be damaged or the integrity of the encapsulation be in question, it is required that a replacement seal cap assembly be ordered from YCC.
- 4) Hardware-- All hardware is stainless steel, and if necessary, should be replaced with the same type.

## FACTORY MUTUAL RESEARCH APPROVED MOTORS

YCC manufactures both Factory Mutual (F/M) Approved motors and non-F/M Approved motors. F/M motors are explosion proof and approved for Class I, Division I, Groups C and D/T3A. Non-F/M motors are of an explosion-proof design, but do not carry third party approval. The motor nameplate carries the F/M logo when F/M motors are purchased. The repair of F/M YCC submersible motors by independent repair shops is permissible. However, to maintain the approved status, strict guidelines for the repair must be adhered to. They are as follows:

- 1) YCC must first be notified prior to any work being done to motor, the nature of the work, and who will complete the work.
- 2) No machining, rework, or redesign to any part or assembly is permitted. **There are no exceptions.**
- 3) All new replacement parts required to reconstruct the motor back to operating condition must be ordered from YCC.
- 4) No changes to or removal of motor nameplates, warning plates, and/or instruction labels is permitted. Replacements are available from YCC. (Damaged plates must be returned to YCC.)

Disregarding these guidelines will result in voiding the Factory Mutual Research Approved status of the motor.

## LONG TERM STORAGE INSTRUCTIONS

The equipment is shipped from the factory with adequate protection for transportation in covered trucks, and for indoor storage at the job site for a limited time between receipt and installation. If the equipment is not put into immediate use, it should be stored in a cool, clean, and dry indoor location. To help prevent rusting, any paint scratches or chips incurred during handling should be touched up prior to storage. Store in the vertical position. Electrical cables must be properly supported and protected from moisture. The rotating assembly must be spun for approximately one (1) minute monthly to insure proper distribution of lubricant and to prevent damage to the shaft, bearings or seals.

## INSTALLATION NOTES

Maximum submergence of motor is not to exceed 150 feet in depth and/or 150 psi working pressure at the motor. Thermal Protectors (Leads marked P1 and P2) must be connected. See Figure 1, Page 11. Moisture Sensing Probes (Leads marked W1 and W2) must be connected. See Figure 2, Page 11. Check power supply against final nameplate connection voltage.

When the submersible motor leaves the factory it is ready for installation, however, during shipping and handling, fasteners may loosen. Verify tightness before installation. No further adjusting, venting or oil filling is required. The motor will operate successfully when the following conditions are met:

- Voltage variation: 10% above or below nameplate data.
- Frequency variation: 5% above or below nameplate data.
- Voltage unbalance: 1% maximum between any two (2) incoming power legs.

Performance within these ranges will not necessarily be the same as the established performance at exact rated voltage and frequency.

The motor should be checked for proper rotation on initial start-up, prior to installation. All 3-phase submersible pump motors will operate in either direction of rotation. To reverse direction of a 3-phase motor, interchange any two motor leads at the starter. All YCC Single Phase submersible pump motors rotate clockwise only (RH) and cannot be reversed.

A lifting bail is supplied for the purpose of installation and servicing. DO NOT USE MOTOR CABLES FOR LIFTING. THIS MAY RESULT IN PERMANENT DAMAGE TO THE CAP AND CABLE ASSEMBLY. Normal care should be exercised to prevent mechanical damage to the seal, the frame, and the insulated cable.

### **CAUTION**

Control leads should not be installed in the same conduit as power leads except where the control leads are supplied in a common cable from the motor. Induced voltage can cause false moisture detection signals. Additionally, junction boxes installed inside wet wells are subject to moisture and condensation. These conditions may produce false moisture detection warnings.

### **START-UP**

YCC motors are designed to run continuously in water or 15 minutes in air. During normal operation, the water level should not be lower than the top of the stator housing of the motor.

The unit is designed to protect all power connections against moisture. All YCC Submersible Motors have a lead connection chamber. Three phase, dual voltage motors have 9 stator leads. In addition, all submersible motors have 2 thermal protector leads and 2 moisture sensing probe leads in this chamber.

Leads are tagged or color coded for easy identification. Appropriate connection diagrams can be found on pages 12 through 15. Most motors can be connected for either high or low voltages. (Some motor ratings are built as single voltage units and as such are not re-connectable.) The cap and cable assembly is available from YCC as a replacement part. When replacing the epoxy seal cap assembly, care should be taken not to nick or damage the o-ring seal. WHEN A REPLACEMENT CAP ASSEMBLY IS REQUIRED, BE SURE TO ORDER FROM YCC OR ITS MOTOR O.E.M. USING MOTOR NAMEPLATE IDENTIFICATION NUMBERS.

### **SPECIAL CONSIDERATION**

If optional tungsten carbide seals have been provided with the motor, a run-in period is necessary prior to placing the pump into service. The motor must be positioned such that the lower seal is continuously submerged during the run-in period. The motor must be run continuously for a two-hour period while closely monitoring the operating conditions. It is essential that the motor not be operated beyond the boundaries of its performance to avoid overload conditions. The motor's moisture detection and thermal protection systems should be connected during the run-in period.

### **MAINTENANCE**

With proper installation and employment of monitoring devices, frequent inspection of motor seals is not required. Should a malfunction occur, the motor has been equipped with a moisture detection system and thermal protection that will provide advance warning of impending failure, allowing the user to plan corrective maintenance before total failure occurs. Greasing of the bearings is not required as these bearings are prelubricated for at least five years of service without requiring attention. As part of routine maintenance, the following should be performed: Monthly: Measure resistance of moisture sensing circuit as described on page 7, Moisture Seal Probe Test. Every Two Years: Drain and flush seal chamber with new oil as described under Disassembly Instructions – To Inspect or Drain Oil on page 8. Inspect the oil for milky appearance indicating presence of water. Inspect motor seal cap area for any signs of water intrusion. Refill as described under Reassembly Instructions – Lower Seal/Mounting Flange Assembly, subsection D on page 10. Every Five Years: A complete overhaul by a competent service repair shop should include the following: Complete disassembly of motor, clean and inspect all parts including mechanical seals, replace worn or damaged parts, replace ball bearings regardless of condition, replace all o-rings and gaskets, inspect rotor and stator for any signs of abrasion or burned spots on the winding, conduct an insulation test.

### **THERMAL PROTECTION SYSTEM**

#### **IMPORTANT**

YCC SUBMERSIBLE MOTORS ARE EQUIPPED WITH THERMAL PROTECTION DEVICES. FAILURE TO PROPERLY CONNECT OR UTILIZE THIS SYSTEM VOIDS THE MOTOR WARRANTY.

Thermostat leads marked P1 and P2 should be connected in series with the stop button on the 3-wire pilot circuit of the magnetic motor controller, so that the thermostat will open the circuit before dangerous temperatures are reached. Refer to Figure 1, Page 11, for wiring diagram of Thermal Protector.

### **WARNING**

MOTOR CONTROLLER MAY HAVE AUTOMATIC OR MANUAL OVERLOAD RESET. DISCONNECT ALL POWER LEADS TO MOTOR WHEN PERFORMING ANY WORK ON MOTOR. A MANUAL, MOMENTARY START SWITCH IS RECOMMENDED TO PREVENT AUTOMATIC RESTART OF THE MOTOR WHEN THERMOSTAT RESETS.

If current through the thermostats exceeds the values listed in Table 1, an intermediate control circuit relay must be used to reduce the current or the thermostats will not work properly.

<b>Table 1: Maximum Current Capacity of Motor Thermostat</b>		
Volts (VAC)	Continuous Amperes	Inrush Amperes
110-120	3.0	30
220-240	1.5	15
440-480	0.75	7.5
550-600	0.6	6.0

## **MOISTURE DETECTION SYSTEM**

### **IMPORTANT**

**YCC** SUBMERSIBLE MOTORS ARE EQUIPPED WITH MOISTURE DETECTION DEVICES. FAILURE TO PROPERLY CONNECT OR UTILIZE THIS SYSTEM VOIDS THE MOTOR WARRANTY.

Moisture sensing probe leads marked W1 and W2 must be used in conjunction with an induction relay or similar device. This device will detect moisture entering the oil chamber due to leakage past the lower seal and/or a breach of the stator housing. When properly connected to a warning device, the moisture detection system will provide notification of needed corrective maintenance. Refer to Figure 2, Page 11, for wiring diagram of Moisture Sensing Circuit. The integrity of the system requires periodic testing. It should be checked every month by measuring the resistance of the moisture sensing circuit. After disconnecting the moisture probe leads inside the control panel, resistance across the probe leads should measure infinite. If resistance is less than 100,000 ohms, moisture is present inside either the seal chamber or the dry stator portion of the motor.

### **WARNING**

CONTROL LEADS SHOULD **NOT** BE INSTALLED IN THE SAME CONDUIT AS POWER LEADS UNLESS SINGLE MOTOR POWER CABLE INCLUDES CONTROL LEADS. INDUCED VOLTAGE CAN CAUSE FALSE MOISTURE DETECTION SIGNALS.

## Test Procedures:

### Moisture Seal Probe Test

The 140 frame motor includes two moisture probes. The probes are independent of each other and the housing and therefore should read infinite resistance between the probe leads. If water enters the seal chamber, the resistance between the probes decreases until the moisture detection relay sensitivity level is reached, usually at a resistance level less than 100,000 ohms. If the resistance between the moisture probe leads is less than 100,000 ohms, water has either entered the seal chamber and mixed with the oil or water has accumulated in the dry portion of the motor where the moisture probe leads connect to the probes.

### Signal Device(s) for Moisture Notification

The signal device may be audible (bell, buzzer, horn or siren) or visible (incandescent or neon lamp) or both.

### Megger Test

Meggers are normally used for trend analysis, whereby newly installed electrical equipment is measured to establish a base of values in resistance, which are recorded along with numerous other relevant variables. Thereafter, readings are periodically taken and recorded along with temperature, moisture, and the length of time the megger was connected to obtain readings. This procedure must be continued for an extended period of time in order to determine that the declining rate of insulation breakdown is not accelerating at an unacceptable level. This test should be taken between the power leads and ground and **NEVER ACROSS THE MOISTURE DETECTION OR THERMAL PROTECTION CIRCUITS**. With periodic monitoring of the moisture-sensing probe as part of a regular schedule of preventive maintenance, it is unnecessary to perform a megger test. However, if a megger test is performed, a resistance of 2 megOhms or less indicates maintenance is needed.

### System Operation

It is required that immediately upon indication (by warning light, etc.) of moisture inside the motor that the motor be removed from the installation and the oil be replaced as soon as possible. The water may have entered by one of several paths, therefore changing the oil and putting the unit back in service is recommended before replacing the lower seal. If the oil appears milky, indicating the presence of water, the oil should be changed and the unit put back in service. Beside the moisture indication circuit, if there is reason to believe the lower seal has leaked, it should be replaced. After changing the oil and a second moisture detection shows that moisture has again entered the motor the lower seal should be closely inspected and replaced if necessary. If a moisture detection indication occurs and no water appears in the oil, water may have entered the motor stator area through an o-ring or some other path, or there may be moisture in a conduit box or in the motor power cable outside the motor. These causes should be investigated carefully.

If reconditioning is not performed within a 30-day period it is then recommended that the upper seal be thoroughly inspected and repaired/replaced if required.

When ordering parts or reporting trouble, please provide complete motor nameplate data.

# DISASSEMBLY INSTRUCTIONS

## WARNING

MOTOR MAY CONTAIN GAS UNDER PRESSURE DUE TO HIGH TEMPERATURES FROM ABNORMAL OPERATION. DISASSEMBLY MAY CAUSE BODILY INJURY.

Refer to Cross Section Drawing (Figure 7).

- 1) Remove cap screws (26) securing epoxy seal cap (9).
- 2) Disconnect all leads and grounding wire. Remove epoxy seal cap assembly.

### Inspecting or Draining Oil:

Lower seal cavity is oil filled. Oil can be drained by removing pipe plug (25).

### Inspecting Lower Seal:

- 1) Place motor with output shaft in up position.
- 2) Remove lower seal snap ring (12)
- 3) Remove lower seal rotating element (13).
- 4) Thoroughly clean the recess and visually inspect seal. If mating faces do not show excessive wear, replacement is not required.

### Inspecting Upper Seal:

- 5) Remove pipe plug (25) and drain oil.
- 6) Remove cap screws (22) from thrust bearing housing (5) and remove lower seal housing (4).
- 7) Remove upper seal snap ring (15) and upper seal rotating element (16).
- 8) Thoroughly clean the chamber and visually inspect seal. If mating faces do not show excessive wear, replacement is not required.

### Thrust Bearing Replacement:

- 9) Rotate motor to output shaft in down position.
- 10) Remove epoxy seal cap (9), and make sure moisture probe leads (32) are free to pull through holes or channels around stator (2).
- 11) Remove cap screws (46) and lift thrust bearing cap (6). Clean portion of shaft protruding from thrust bearing (10) and lubricate with oil. Remove snap ring (44) on shaft by short bearing spacer (56) below thrust bearing (10).
- 12) Remove socket head cap screws (23) carefully and remove stator housing assembly from thrust bearing housing/rotor/shaft assembly, allowing moisture probe leads (32) to pull through the holes or channels around stator (2).
- 13) Using a suitable bearing puller, remove thrust bearing (10). Remove long thrust bearing spacer (55) from shaft and slide thrust bearing housing (5) from shaft/rotor assembly.

### Final Disassembly:

- 14) Using suitable bearing puller, remove radial bearing (11) if necessary.
- 15) Remove stationary seats of the upper (17) and lower (14) seals.

*NOTE:* Rotor & Shaft assembly cannot be further disassembled. Stator cannot be removed from stator housing and must either be repaired or replaced as a unit.



## REASSEMBLY INSTRUCTIONS

- 1) Assemble radial bearing (11) to rotor/shaft assembly.

### CAUTION

WHEN INSTALLING BALL OR ROLLER BEARINGS, PRESS ONLY AGAINST INNER RACES OF BEARINGS. PRESSING ON OUTER RACES WILL DAMAGE ROLLING ELEMENTS AND DAMAGE THE BEARING. PRESS EVENLY ON BEARING INNER RACE, USING EXTREME CARE NOT TO SCORE SHAFT.

It may be necessary to heat bearings to facilitate installation because of close tolerance fits. Bearings may be heated by either of the following methods:

**OIL BATH:** Accomplished by submerging bearing in a tank of oil having a high flash point. The bearing should be suspended so as not to be in contact with the heat source, for 20 to 30 minutes at a temperature of approximately 200°F. Oil temperature must not exceed 250°F.

**INDUCTION HEATING:** Accomplished by applying heat directly to the bearing (i.e., commercially available induction bearing heater). Extreme caution must be exercised to insure that bearing temperature does not exceed 200°F.

The bearings should be quickly installed and positioned squarely against mating face while still hot, and secured with appropriate retaining ring.

### WARNING

SUITABLE PROTECTIVE CLOTHING (I.E. GLOVES) MUST BE WORN WHEN HANDLING HEATED COMPONENTS.

- 2) Place o-rings (18), (19) & (28) in their grooves. Lightly coat all o-rings with a suitable lubricant (such as that listed on page 10. Alternatively, grease may be substituted (not excessive).
- 3) Thrust Bearing Housing Assembly--
  - A) Check that moisture sensor probes (21) are intact and connected to probe wiring leads (30). If the probes are damaged or not connected, they cannot be repaired and the thrust bearing housing must be replaced as an assembly including the probes (5).
  - B) Pre-pack thrust bearing (10) with lithium based grease. Do not over grease. FOR HI-TEMP APPLICATIONS: Use Chempet B-2 Grease NLGI Grade.
  - C) Lightly lubricate upper seal stationary seat o-ring (17) with recommended seal lubricant or oil (page 10). Make certain lapped face is exposed. Now, using a suitable pressing tool, carefully press upper seal stationary seat into thrust bearing cap (6) until properly positioned.
  - D) Install snap ring (58) into thrust bearing housing (5).
  - E) Lower reassembled rotating assembly (Re-assembly Instruction 1, above) into thrust bearing housing (5). Install long thrust bearing spacer (55) onto shaft, followed by the thrust bearing (10). While supporting the thrust bearing housing (5) install the short thrust bearing spacer (56) onto the shaft (3) and secure thrust bearing and spacer with retaining ring (44) in groove in the shaft (5).
  - F) Making sure o-ring (18) is properly positioned, assemble thrust bearing cap (6) to thrust bearing housing (5) using socket head cap screws (46).
  - G) Pre-pack radial bearing (11) with lithium based grease such as Mobilux EP2 or equal. Do not over-grease. FOR HI-TEMP APPLICATIONS: Use Chempet B-2 Grease NLGI Grade.
  - H) Place radial bearing wavy washer into radial bearing cavity in stator/radial bearing housing (7).

- l) Lower rotating assembly with thrust bearing housing into stator, pulling W1 and W2 lead wires (32) through cored channel in housing. Carefully align radial bearing with cavity in radial bearing/stator housing assembly. Bolt stator housing (7) to thrust bearing housing (5) with cap screws (23), making sure the o-ring (19) is not damaged and is properly seated.
- 4) Lower Seal/Mounting Flange Assembly--
- A) Place motor assembly with output shaft in up position. Thoroughly clean seal cavity and probes. Lightly lubricate rubber parts of upper seal rotating element (16) and shaft (3) with recommended seal lubricant or oil. Slide complete upper seal rotating element (16) onto shaft (3). Firmly push into position and install upper seal snap ring (15) on shaft (3) using a suitable tool. Turn shaft by hand to make sure seal is properly seated.
  - B) Reinstall lower stationary seat (14) and o-ring, making sure it is properly seated. Follow steps outlined in Paragraph 3) C) above.
  - C) Assemble lower seal housing (4) to thrust bearing housing (5) and secure with cap screws (22). Make sure o-ring (28) is properly seated before tightening. Thoroughly clean seal cavity. Complete lower seal rotating element (13) and lower seal snap ring (12) following the procedure outlined in Paragraph 4) A) above. When complete, turn shaft by hand to make sure seals are properly seated.
  - D) Add required quantity of recommended oil to lower seal cavity (Refer to Table 2 for recommended oil quantities). This can be accomplished with the output shaft in the horizontal position, filling and venting through pipe plug (25). The oil level should be even with the bottom of the pipe plug (25) with the motor in the horizontal position and the hole vertical on top. Oil level cannot be checked with the motor in the output shaft down position.
- 6) Cable Cap Assembly--
- A) Rotate motor to output shaft in down position.
  - B) Place o-ring (20) over fit and lightly coat with grease (not excessive).
  - C) Reconnect power and control wires using applicable connection diagram on pages 12 through 15.
  - D) Secure epoxy seal cap (9) to stator/radial bearing housing (7) using screws (26), making sure o-ring (20) is properly seated.

TABLE 2	
RECOMMENDED OIL QUANTITIES	
MOTOR FRAME	QUANTITY
140	1 pint

TABLE 3	
RECOMMENDED OIL	
MANUFACTURER	BRAND NAME
Petro Canada	Petro Canada 10W
CITGO	Citgard 10W

Recommended Grease for Bearings: CITGO Lithium EP-2 or Equivalent

## MAINTENANCE DATA FOR MECHANICAL SEALS

Applicable Products: YCC Submersible Motors

Applicable Seals: Type 21 or equivalent.

MOTOR FRAME	SIZE	
	UPPER SEAL	LOWER SEAL
140	32mm	32mm

Cleaning Solvent: Denatured Ethyl Alcohol Solvent Formula CDA 19

Seal Installation Lubricant: Water or water based seal installation lubricant such as P-80 Rubber Lubricant.  
(Do Not Use Oil or Grease as a Seal Lubricant)

# FIGURE 1

## TYPICAL THERMAL PROTECTOR WIRING DIAGRAM

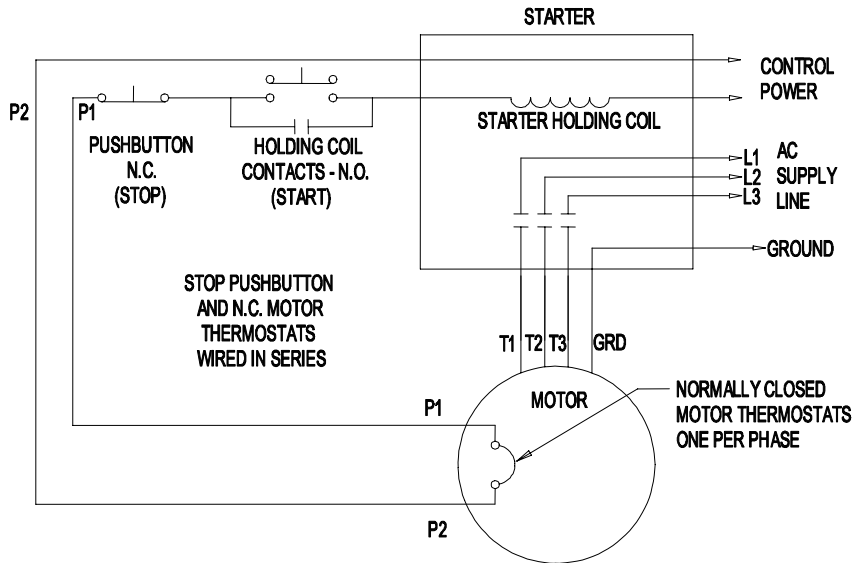

# FIGURE 2

## TYPICAL MOISTURE SENSING CIRCUIT WIRING DIAGRAM

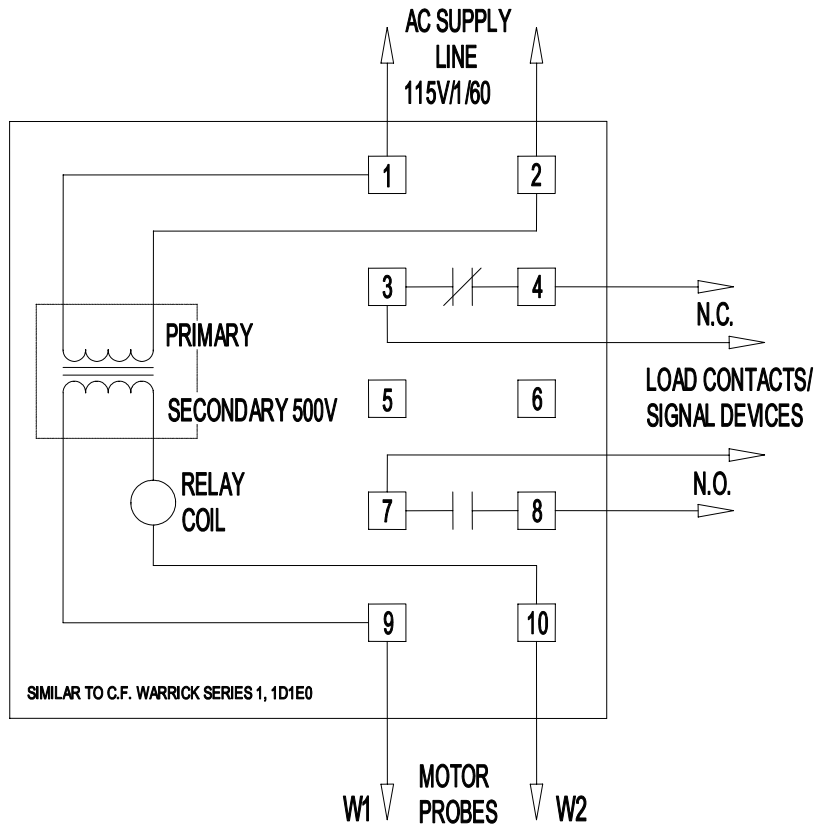

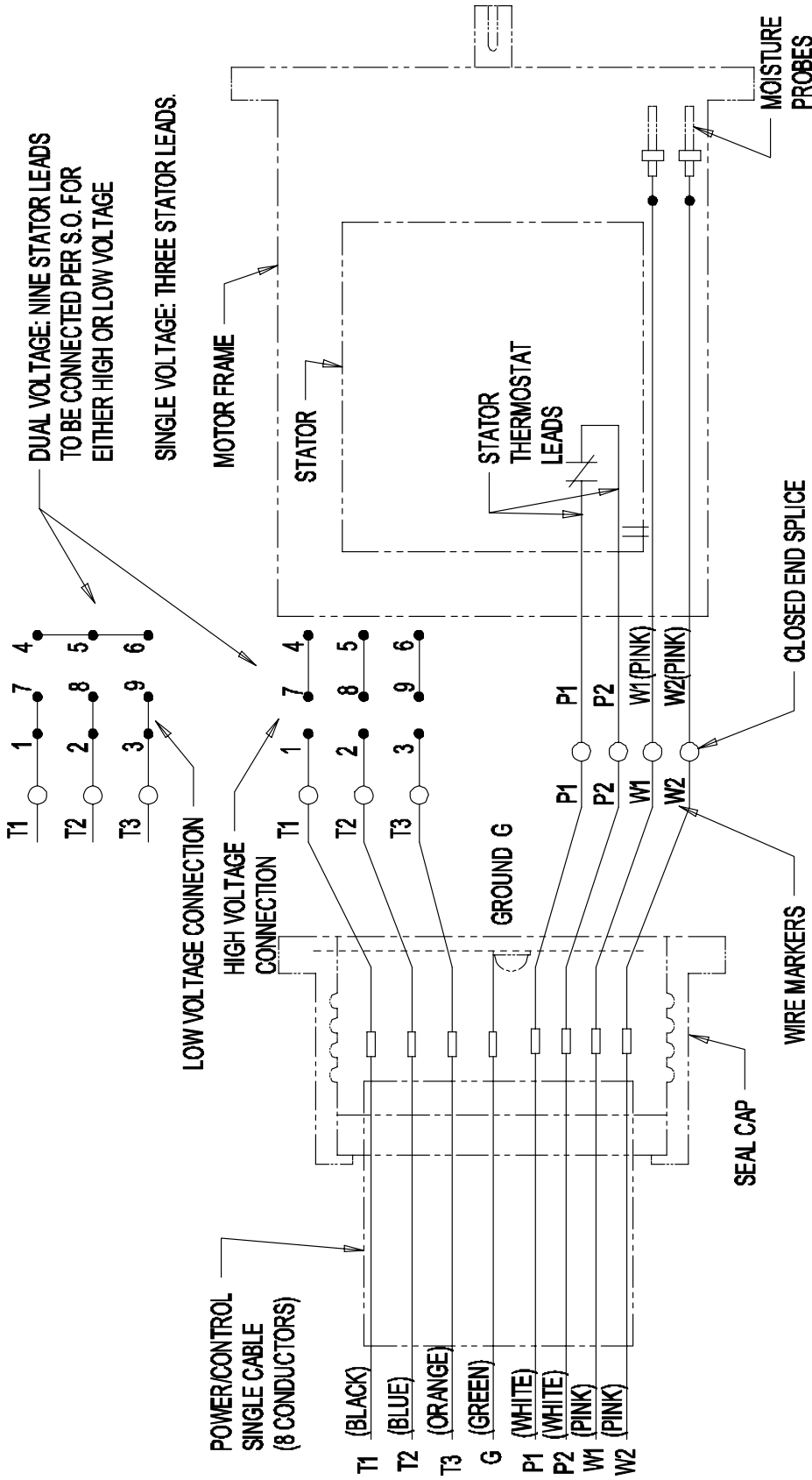

5/29/01

FIGURE 3

SEAL CAP AND MOTOR WIRING DIAGRAM  
TYPICAL FOR SINGLE CABLE 3-PHASE MOTOR

FILE NAME 110257

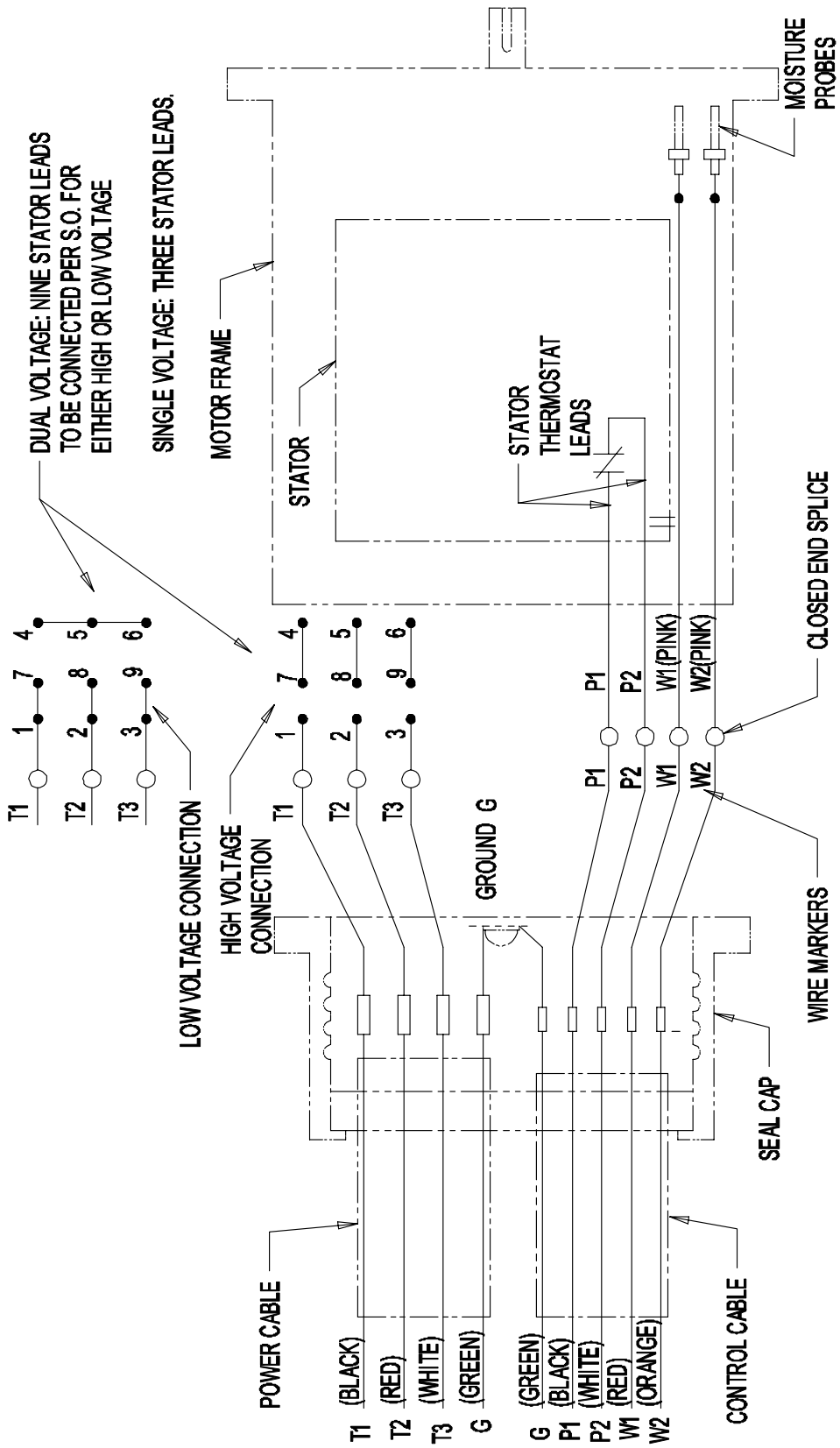

6/4/01

**FIGURE 4**  
**SEAL CAP AND MOTOR WIRING DIAGRAM**  
**TYPICAL FOR DUAL CABLE 3-PHASE**

FILE NAME 110258

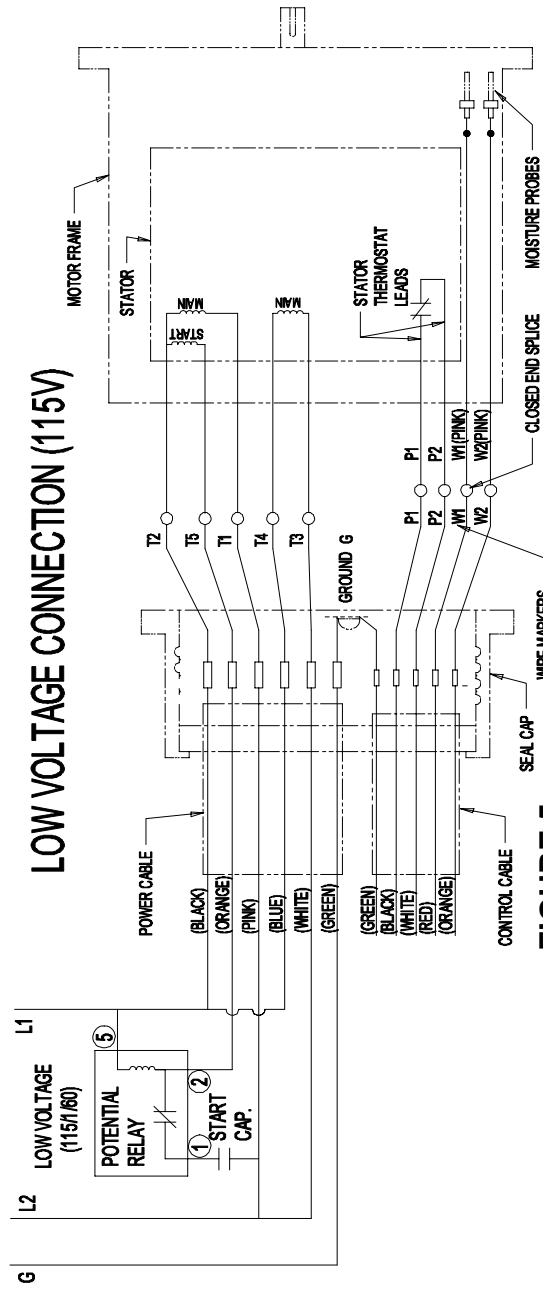
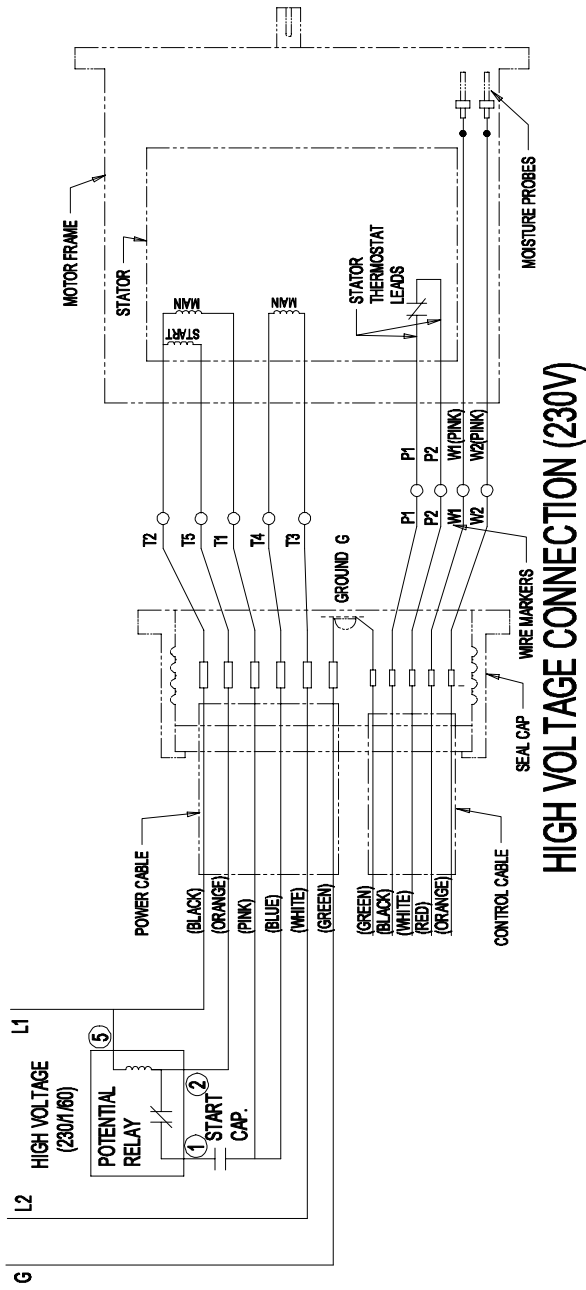

**FIGURE 5**  
 SEAL CAP AND MOTOR WIRING DIAGRAM 1/2HP THROUGH 2HP SINGLE PHASE  
 INCLUDING EXTERNAL POWER CONNECTIONS (CAPACITOR START/INDUCTION RUN)

5/29/01

FILE NAME 110256

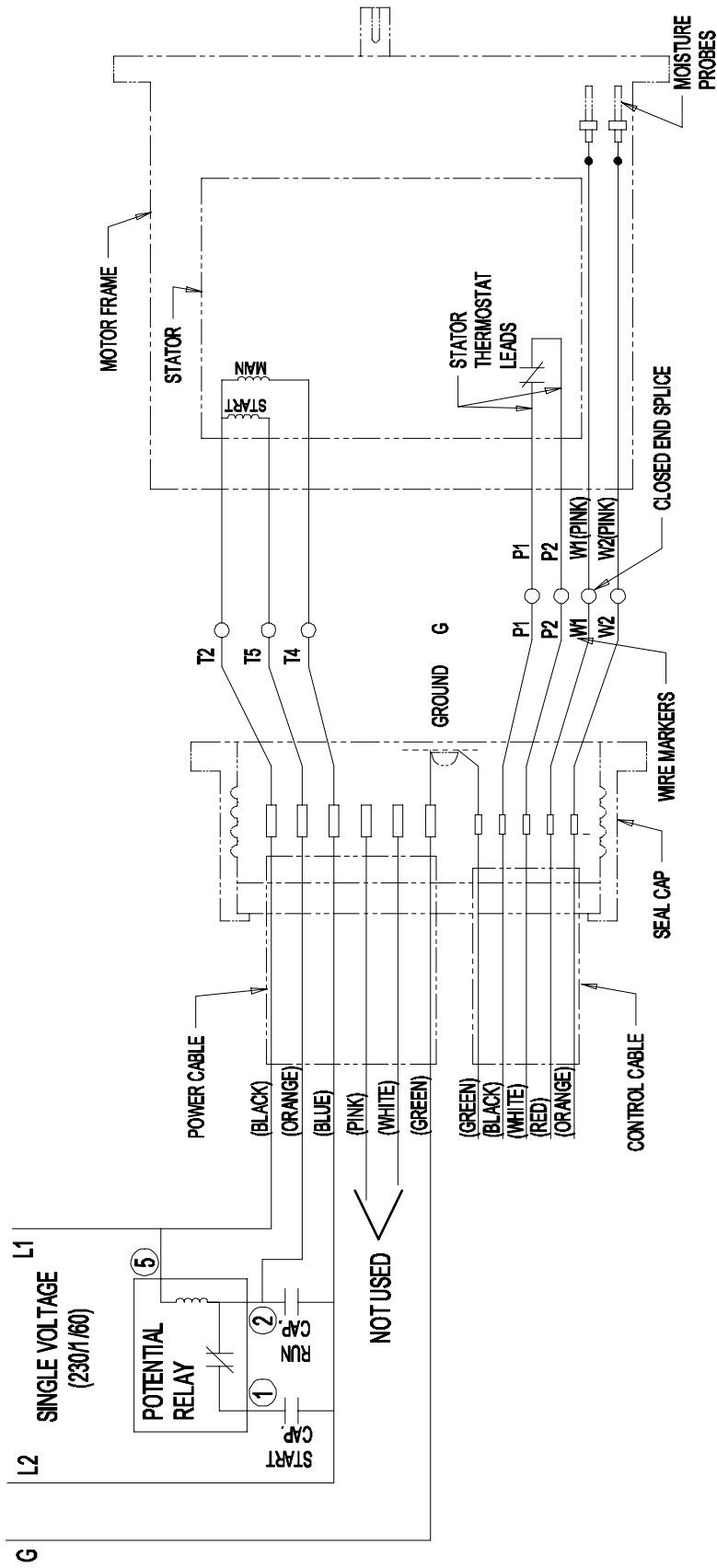

10/1/01

**FIGURE 6**

SEAL CAP AND MOTOR WIRING DIAGRAM  
 3HP AND 5HP SINGLE PHASE  
 INCLUDING EXTERNAL POWER CONNECTIONS  
 (CAPACITOR START/CAPACITOR RUN)

FILE NAME 110269

**FIGURE 7**  
**CROSS SECTION AND**  
**PARTS IDENTIFICATION DRAWING**

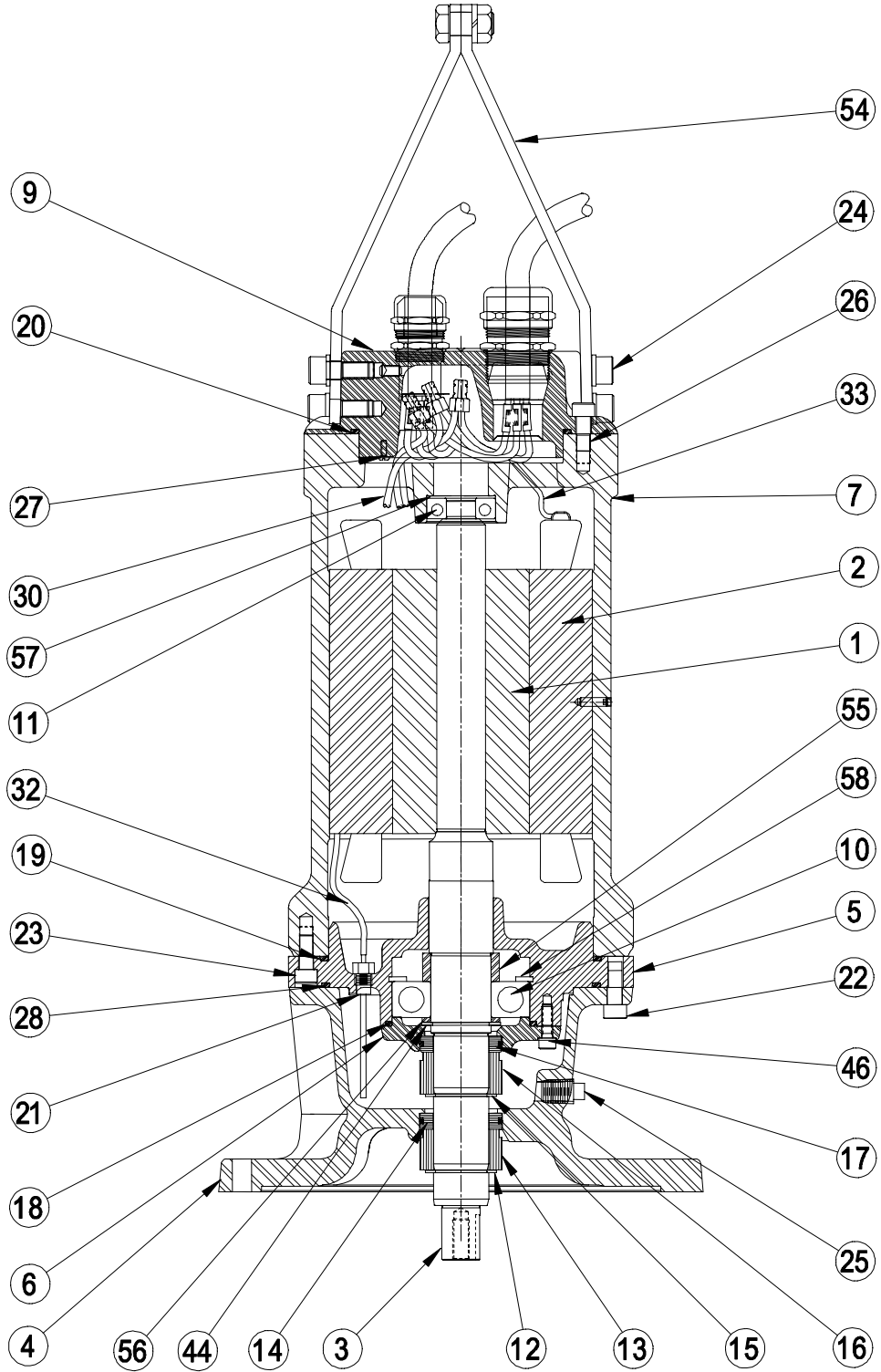

FILE NAME: 111676

**TYPICAL 140 FRAME**

10/1/01



## FIGURE 8

<b>PARTS LIST - 140 FRAME</b>	
NO	DESCRIPTION
1	ROTOR
2	STATOR
3	SHAFT
4	LOWER SEAL HOUSING
5	THRUST BEARING HOUSING
6	THRUST BEARING CAP
7	STATOR & RADIAL BEARING HOUSING
9	EPOXY SEAL CAP ASSEMBLY
10	THRUST BEARING
11	RADIAL BEARING
12	LOWER SEAL SNAP RING
13	LOWER SEAL ROTATING ELEMENT
14	LOWER SEAL STATIONARY SEAT
15	UPPER SEAL SNAP RING
16	UPPER SEAL ROTATING ELEMENT
17	UPPER SEAL STATIONARY SEAT
18	O-RING, THRUST BEARING CAP
19	O-RING, STATOR HOUSING
20	O-RING, EPOXY SEAL CAP
21	MOISTURE PROBES
22	SOCKET HEAD CAP SCREW
23	SOCKET HEAD CAP SCREW
24	SOCKET HEAD CAP SCREW
25	PIPE PLUG, FILL/DRAIN
26	SOCKET HEAD CAP SCREW
27	GROUND SCREW
28	O-RING, LOWER SEAL HOUSING
30	POWER WIRING LEADS
32	PROBE WIRING LEADS
33	THERMAL PROTECTOR LEADS
44	SNAP RING, THRUST BEARING I.D.
46	SOCKET HEAD CAP SCREW
54	LIFTING BAIL
55	SPACER, LONG, THRUST BEARING
56	SPACER, SHORT, THRUST BEARING
57	WAVY WASHER, RADIAL BEARING
58	SNAP RING, THRUST BEARING O.D.

FILE NAME: 111676

10/1/01

## **ADDENDUM**

### **MECHANICAL SEAL INSTRUCTION – SUBMERSIBLE**

The mechanical seals used on motors manufactured by YCC are purchased commercially from various suppliers that make interchangeable seals. The most common types are called the John Crane Type 21, Pac-Seal/Flowserve Type 21-31, and the Burgmann MG9. These seals applied in YCC motors function interchangeably with some minor changes to the mounting details. **DO NOT ASSUME A REPLACEMENT SEAL MOUNTS IDENTICALLY TO AN EXISTING SEAL.** The retainers for all seals have been updated to accommodate different seals and springs. Some seals use a spring holder, which looks like a thin washer, some use a retaining ring alone. The replacement seal is supplied with the correct retaining components. Note the conical spring and its orientation.

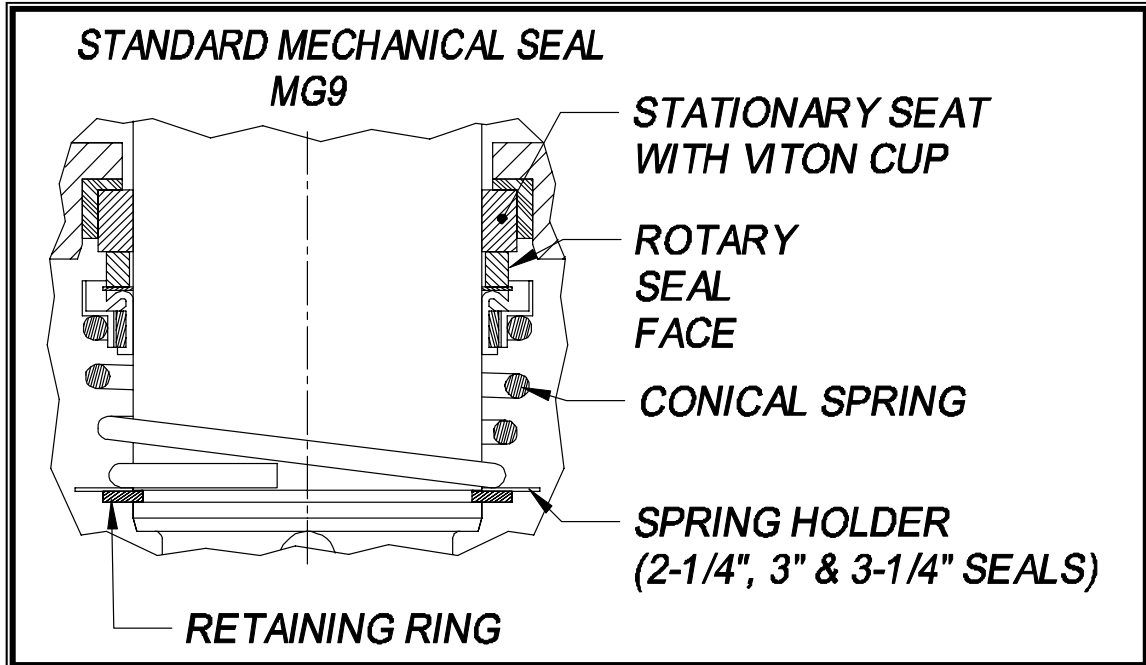

Note: Protect lapped seal faces from contamination or damage during handling and installation. Never use grease or heavy motor oil as a seal installation lubricant. Oil, grease or dirt on the seal faces may cause leakage. The seal chamber is oil filled at the factory. Take suitable precautions to collect spillage and avoid injury from spray if pressure causes oil to spray when motor is opened.

1. Disassemble pump to expose seal. Lower seal housing will need to be removed to service upper seal. Note assembly and mounting of existing seal. New seal should mount similar but may require additional components such as spring holder or different retaining ring.
2. Carefully remove old seal rotary and stationary components taking care not to damage shaft or housing bore.
3. Clean shaft and housing bore with very fine emery cloth to remove rust and burrs, but avoid making flat spots or reducing the shaft diameter.
4. Lubricate the shaft and housing bore and the seal's Viton elastomer components only with water based seal lubricant. Seal faces should not be lubricated.
5. Press stationary seal seat firmly into housing bore. Protect seal face with plastic or cardboard.
6. Check both seal faces for contamination by lubricant or particles. Slide rotary seal components by hand pressure along shaft to insure completely parallel contact with stationary seat. Make sure spring properly engages step on rotary seal and opposite end of spring either rests against spring retainer or sits on the retaining ring. See sketch above.
7. Reassemble motor and pump replacing any components supplied in kit if applicable.
8. When pump is started, submersible wet pit type pumps will vent and purge air pockets automatically without intervention. Never run pump dry.

## YCC SUBMERSIBLE MOTOR DATA - 4 POLE

Totally enclosed, non-ventilated, hermetically sealed submersible type. Features include 416 stainless steel shaft, tandem mechanical seals (one inside an oil chamber and one outside); automatic reset N.C. series connected thermal overload protection, two moisture sensing probes, prelubricated shaft bearings designed for L-10 life of 25,000 hours, and class F insulation. \*Efficiencies include all mechanical losses including mechanical seals.

H.P.	Full Load RPM	Frame Size	Nominal Eff % @ *			Nominal Power			Amps @ 460V		KVA Code Letter	Full Load Torque (Ft Lbs)	% Full Load		Power Cable		Control Cable	
			Full Load	3/4 Load	1/2 Load	Full Load	3/4 Load	1/2 Load	Full Load	Locked Rotor			Locked Rotor	Break-down	AWG Size	O.D. ** (in.)	AWG Size	O.D. ** (in.)
0.5	1732	140	55.7	50.1	41.1	75.6	69.3	61.2	1.1	6.1	L	1.5	313	368	#16	0.57	Not Applicable	
0.75	1733	140	63.9	58.9	50.3	76.8	70.4	61.8	1.4	8.5	K	2.3	302	356	#16	0.57		
1	1739	140	68.3	63.7	55.4	75.6	68.8	59.5	1.8	11.5	L	3.0	308	371	#16	0.57		
1.5	1737	140	72.3	68.5	61.1	76.7	69.8	58.9	2.5	15.4	K	4.5	268	332	#16	0.57		
2	1744	140	74.9	72.7	66.6	75.7	67.4	55.2	3.3	19.8	J	6.0	267	319	#12	0.65	#18	0.45
3	1733	140	77.7	76.2	71.0	79.9	73.1	61.6	4.5	26.8	J	9.0	199	288	#12	0.65	#18	0.45
5	1733	140	80.6	79.4	74.6	81.1	74.7	63.6	7.1	45.1	J	15.0	244	301	#12	0.65	#18	0.45
7.5	1736	180	85.6	87.2	86.9	84.3	78.8	68.0	9.7	63.3	H	22.7	225	304	#8	0.99	#14	0.59
10	1735	180	85.3	86.8	86.1	80.6	73.3	60.4	13.6	83.7	H	30.3	229	302	#8	0.99	#14	0.59
15	1747	210	86.7	88.6	88.6	81.4	76.4	66.1	19.9	104.8	F	45.1	192	239	#8	0.99	#14	0.59
20	1741	210	86.4	88.9	89.6	82.4	78.6	69.6	26.3	131.1	F	60.3	183	223	#4	1.27	#14	0.59
25	1761	250	88.8	90.3	90.2	83.8	80.6	72.2	31.4	172.1	F	74.6	192	236	#4	1.27	#14	0.59
30	1763	250	89.5	90.8	90.8	84.1	80.9	72.7	37.3	217.2	G	89.4	206	248	#4	1.27	#14	0.59
40	1757	250	89.2	91.1	91.5	84.7	82.2	75.0	49.6	273.0	F	119.6	197	234	#2	1.48	#14	0.59
50	1771	320	89.3	89.4	87.6	82.1	77.6	67.7	64.0	345.0	F	148.3	175	252	#4	1.27	#14	0.59
60	1767	320	90.3	90.9	90.0	87.9	86.8	82.1	71.0	378.0	F	178.3	167	229	#4	1.27	#14	0.59
75	1774	320	92.1	92.3	91.3	87.8	86.2	80.2	87.0	560.0	G	222.1	205	275	#2	1.48	#14	0.59
100	1784	360	92.8	92.6	91.0	86.9	85.2	79.5	116.0	762.0	G	294.4	187	287	2/0	1.93	#14	0.59
125	1782	360	93.2	93.2	92.0	86.9	85.4	80.1	145.0	901.0	G	368.5	178	263	2/0	1.93	#14	0.59
150	1782	360	93.6	93.8	92.8	88.5	87.2	83.0	169.0	1108.0	G	442.1	186	268	2-#2	1.48 each	#14	0.59
200	1780	L360	94.6	95.1	94.8	88.1	88.7	86.8	225.0	1297.0	F	590.0	165	234	2-#1	1.68 each	#14	0.59

Typical motor data for Submersible 3 phase, 60 hertz, Nema design B, 40 °C ambient, normal torque motors. Amperes shown for 460 volt connection. If other connections are available, the amperes will vary inversely with rated voltage. All values nominal. All motors have 1.15 S.F. at 40 °C ambient temperature.

\*\* Above cable data for standard motors only, with cable length of 25'. Data applicable through lengths of 100'. Control cables must be run in a separate conduit. 140 frame motors with #16 AWG cord utilize single cable, (8) conductor, with power and control leads.

May, 2001

## YCC SUBMERSIBLE MOTOR DATA - 6 POLE

Totally enclosed, non-ventilated, hermetically sealed submersible type. Features include 416 stainless steel shaft, tandem mechanical seals (one inside an oil chamber and one outside); automatic reset N.C. series connected thermal overload protection, two moisture sensing probes, prelubricated shaft bearings designed for L-10 life of 25,000 hours, and class F insulation. \*Efficiencies include all mechanical losses including mechanical seals.

H.P.	Full Load RPM	Frame Size	Nominal Eff % @ *			Nominal Power			Amps @ 460V		KVA Code Letter	Full Load Torque (Ft Lbs)	% Full Load		Power Cable		Control Cable	
			Full Load	3/4 Load	1/2 Load	Full Load	3/4 Load	1/2 Load	Full Load	Locked Rotor			Locked Rotor	Break-down	AWG Size	O.D. ** (in.)	AWG Size	O.D. ** (in.)
0.5	1150	140	61.7	46.7	48.1	65.0	58.0	49.0	1.2	5.2	K	2.3	254	310	#16	0.57	Not Applicable	
0.75	1151	140	67.2	62.9	54.9	65.0	58.0	48.0	1.6	7.3	J	3.4	234	295	#16	0.57		
1	1152	140	70.8	67.0	59.5	65.0	57.0	47.0	2.0	9.4	J	4.5	229	293	#16	0.57		
1.5	1154	140	73.9	70.6	63.7	64.0	56.0	45.0	3.0	13.9	J	6.8	220	290	#12	0.65	#18	0.45
2	1160	140	76.2	72.8	65.9	60.0	52.0	41.0	4.1	20.2	K	9.0	241	323	#12	0.65	#18	0.45
3	1153	140	79.0	76.8	71.2	65.0	56.0	44.0	5.5	25.7	H	13.5	205	277	#12	0.65	#18	0.45
5	1147	180	79.5	81.2	80.0	67.0	58.0	45.4	8.8	35.2	G	22.9	161	228	#12	0.65	#14	0.59
7.5	1133	180	79.8	81.9	81.2	73.3	64.6	50.9	12.0	51.1	F	34.8	149	224	#8	0.99	#14	0.59
10	1156	210	84.0	85.8	85.4	70.7	63.3	51.0	15.8	75.3	G	45.4	212	237	#8	0.99	#14	0.59
15	1158	250	85.8	87.5	87.2	77.6	71.1	58.9	21.1	89.1	E	68.0	150	210	#4	1.27	#14	0.59
20	1164	250	87.2	89.0	89.0	80.8	75.8	65.0	26.6	124.6	E	90.3	160	220	#4	1.27	#14	0.59
25	1162	250	87.7	89.6	89.8	80.8	76.1	65.8	33.0	152.8	E	113.0	162	217	#4	1.27	#14	0.59
30	1168	320	86.8	87.5	86.2	81.7	77.6	68.6	40.0	207.0	F	134.9	186	233	#4	1.27	#14	0.59
40	1171	320	88.3	89.4	88.6	84.1	81.0	73.4	50.0	289.0	G	179.4	198	240	#4	1.27	#14	0.59
50	1174	320	89.3	90.4	90.1	85.3	82.9	76.4	62.0	368.0	G	223.8	204	240	#4	1.27	#14	0.59
60	1173	320	89.0	89.9	89.1	79.7	74.5	63.8	79.0	483.0	H	268.6	228	266	#4	1.27	#14	0.59
75	1178	360	90.7	91.2	90.3	83.8	79.9	70.9	92.0	570.0	G	334.5	146	291	#2	1.48	#14	0.59
100	1173	360	90.6	91.7	91.3	84.8	81.7	73.7	122.0	681.0	F	447.6	133	260	2/0	1.93	#14	0.59
125	1175	360	91.2	92.3	92.1	85.0	81.8	73.6	151.0	913.0	G	558.8	147	280	2/0	1.93	#14	0.59
150	1175	L360	92.9	94.4	95.1	86.0	83.4	76.2	175.7	1059.0	G	670.7	146	275	2-#2	1.48each	#14	0.59

Typical motor data for Submersible 3 phase, 60 hertz, Nema design B, 40 °C ambient, normal torque motors. Amperes shown for 460 volt connection. If other connections are available, the amperes will vary inversely with rated voltage. All values nominal. All motors have 1.15 S.F. at 40 °C ambient temperature.

\*\* Above cable data for standard motors only, with cable length of 25'. Data applicable through lengths of 100'. Control cables must be run in a separate conduit. 140 frame motors with #16 AWG cord utilize single cable, (8) conductor, with power and control leads.

May, 2001

## YCC SUBMERSIBLE MOTOR DATA - 8 POLE

Totally enclosed, non-ventilated, hermetically sealed submersible type. Features include 416 stainless steel shaft, tandem mechanical seals (one inside an oil chamber and one outside); automatic reset N.C. series connected thermal overload protection, two moisture sensing probes, prelubricated shaft bearings designed for L-10 life of 25,000 hours, and class F insulation. \*Efficiencies include all mechanical losses including mechanical seals.

H.P.	Full Load RPM	Frame Size	Nominal Eff % @ *			Nominal Power			Amps @ 460V		KVA Code Letter	Full Load Torque (Ft Lbs)	% Full Load		Power Cable		Control Cable	
			Full Load	3/4 Load	1/2 Load	Full Load	3/4 Load	1/2 Load	Full Load	Locked Rotor			Locked Rotor	Break-down	AWG Size	O.D. ** (in.)	AWG Size	O.D. ** (in.)
0.5	864	140	58.7	53.2	44.1	51.0	44.0	36.0	1.6	5.6	K	3.0	265	320	#16	0.57	Not Applicable	
0.75	862	140	64.1	59.3	50.7	52.0	45.0	36.0	2.1	7.6	K	4.5	239	295	#16	0.57		
1	863	140	68.4	64.2	56.2	53.0	45.0	36.0	2.6	9.7	J	6.0	229	288	#16	0.57		
1.5	861	140	72.1	68.6	61.3	54.0	45.0	36.0	3.6	13.8	J	9.0	221	278	#12	0.65	#18	0.45
2	862	140	74.8	71.6	64.7	52.0	44.0	34.0	4.8	18.5	J	12.0	226	285	#12	0.65	#18	0.45
3	874	210	83.9	83.1	79.7	62.2	53.5	41.4	5.4	31.6	K	18.0	203	360	#12	0.65	#18	0.45
5	869	210	83.4	83.0	79.9	59.3	50.6	38.7	9.5	46.3	J	30.2	193	318	#12	0.65	#14	0.59
7.5	858	210	82.8	83.8	82.2	65.4	56.9	44.6	13.0	57.2	G	45.9	160	260	#12	0.65	#14	0.59
10	878	250	86.2	86.6	85.0	68.1	60.0	47.9	15.9	72.5	G	59.8	177	244	#4	1.27	#14	0.59
15	870	250	85.6	87.4	87.0	72.3	66.3	54.6	22.7	85.2	E	90.5	137	191	#4	1.27	#14	0.59
20	863	250	85.1	87.0	86.8	73.9	67.0	54.9	29.8	145.5	G	121.7	137	248	#4	1.27	#14	0.59
25	880	320	88.2	89.4	88.8	77.6	74.0	65.2	34.0	162.0	F	149.1	150	199	#4	1.27	#14	0.59
30	881	320	88.5	89.7	89.2	77.3	73.3	64.0	41.0	201.0	F	178.9	159	205	#4	1.27	#14	0.59
40	880	320	88.4	89.9	89.7	76.7	72.6	63.1	55.0	263.0	F	238.8	162	200	#4	1.27	#14	0.59
50	881	360	88.2	89.4	88.8	76.9	70.9	59.2	69.0	344.0	F	298.2	122	247	#4	1.27	#14	0.59
60	881	360	89.1	90.3	89.9	77.1	71.2	59.6	82.0	425.0	G	357.7	129	257	#4	1.27	#14	0.59
75	881	360	89.1	90.3	89.9	75.8	69.0	56.7	104.0	543.0	G	447.3	137	262	#2	1.48	#14	0.59
100	881	360	89.9	91.0	90.7	75.9	69.1	56.6	137.0	745.0	G	596.2	144	273	2/0	1.93	#14	0.59
125	880	360	90.2	91.7	91.8	77.9	71.9	60.0	167.0	913.0	G	745.9	146	267	2/0	1.93	#14	0.59

Typical motor data for Submersible 3 phase, 60 hertz, Nema design B, 40 °C ambient, normal torque motors. Amperes shown for 460 volt connection. If other connections are available, the amperes will vary inversely with rated voltage. All values nominal. All motors have 1.15 S.F. at 40 °C ambient temperature.

\*\* Above cable data for standard motors only, with cable length of 25'. Data applicable through lengths of 100'. Control cables must be run in a separate conduit. 140 frame motors with #16 AWG cord utilize single cable, (8) conductor, with power and control leads.

May, 2001

## YCC SUBMERSIBLE MOTOR DATA - SINGLE PHASE

Totally enclosed, non-ventilated, hermetically sealed submersible type. Features include 416 stainless steel shaft, tandem mechanical seals (one inside an oil chamber and one outside); automatic reset N.C. series connected thermal overload protection, two moisture sensing probes, prelubricated shaft bearings designed for L-10 life of 25,000 hours, and class F insulation. \*Efficiencies include all mechanical losses including mechanical seals.

H.P.	Full Load RPM	Frame Size	Nominal Eff % @ *			Nominal Power			Amps @ 230V		KVA Code Letter	Full Load Torque (Ft-Lbs)	% Full Load		Power Cable		Control Cable	
			Full Load	3/4 Load	1/2 Load	Full Load	3/4 Load	1/2 Load	Full Load	Locked Rotor			Locked Rotor	Break-down	AWG Size	O.D. ** (in.)	AWG Size	O.D. ** (in.)
0.5																		
0.75																		
1	1735	140	62.1	57.8	49.7	76.0	70.0	61.0	6.9	31.3	J	3.0	289	251	#10	0.8	#18	0.45
1.5	1729	140	66.8	63.7	56.7	79.0	73.0	63.0	9.2	38.6	G	4.5	235	223	#10	0.8	#18	0.45
2	1730	140	69.8	67.2	60.7	79.0	73.0	63.0	11.7	48.4	F	6.0	217	220	#10	0.8	#18	0.45
3	1734	140	76.7	72.7	64.4	100.0	100.0	100.0	12.7	58.8	E	9.0	227	229	#10	0.8	#18	0.45
5	1725	140	79.0	77.0	70.8	97.0	97.0	96.0	21.1	83.7	C	15.0	147	201	#10	0.8	#18	0.45

H.P.	Full Load RPM	Frame Size	Nominal Eff % @ *			Nominal Power			Amps @ 230V		KVA Code Letter	Full Load Torque (Ft-Lbs)	% Full Load		Power Cable		Control Cable	
			Full Load	3/4 Load	1/2 Load	Full Load	3/4 Load	1/2 Load	Full Load	Locked Rotor			Locked Rotor	Break-down	AWG Size	O.D. ** (in.)	AWG Size	O.D. ** (in.)
0.75	1146	140	55.1	50.1	41.5	59.0	52.0	44.0	7.4	27.1	K	3.4	353	239	#10	0.8	#18	0.45
1	1149	140	58.5	53.7	45.3	59.0	52.0	43.0	9.4	35.4	K	4.5	335	242	#10	0.8	#18	0.45
1.5	1149	140	61.0	56.6	48.3	59.0	51.0	42.0	13.6	43.8	H	6.8	254	233	#10	0.8	#18	0.45
2	1152	140	73.5	68.8	59.8	95.0	94.0	91.0	9.3	43.1	E	9.0	270	230	#10	0.8	#18	0.45
3	1146	140	75.0	71.7	64.0	88.0	85.0	78.0	14.7	53.5	D	13.5	197	205	#10	0.8	#18	0.45

Typical motor data for Submersible 1 phase, 60 hertz, Nema design B, 40 °C ambient, normal torque motors. Amperes shown for 230 volt connection. If other connections are available, the amperes will vary inversely with rated voltage. All values nominal.

\*\* Above cable data for standard motors only, with cable length of 25'. Data applicable through lengths of 100'. Control cables must be run in a separate conduit.