

# Performance curves

UP 53-46  
1 phase 115 V/230 V, 60 Hz

## Performance curves

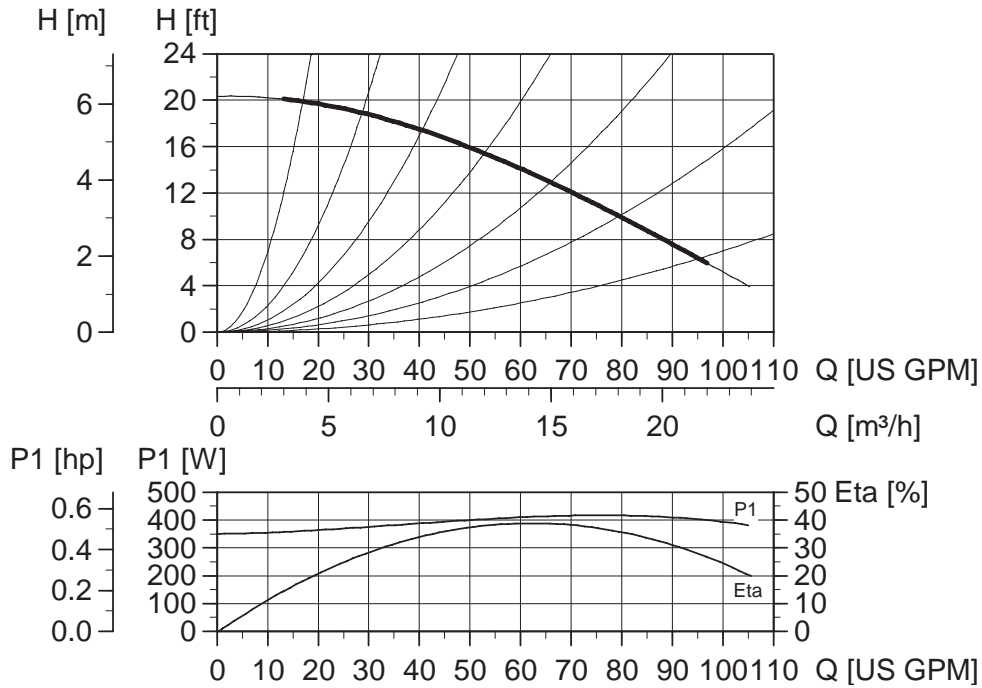

Note: ETA is calculated as wire-to-water efficiency.

## Weights and volume

|                 | Cast Iron |                 |      |                | Bronze |                 |      |                |
|-----------------|-----------|-----------------|------|----------------|--------|-----------------|------|----------------|
|                 | lbs.      | ft <sup>3</sup> | Kg   | m <sup>3</sup> | lbs.   | ft <sup>3</sup> | Kg   | m <sup>3</sup> |
| Net weight      | 44.5      |                 | 20.2 |                | 49.2   |                 | 22.3 |                |
| Gross weight    | 63.5      |                 | 23.8 |                | 57.1   |                 | 25.9 |                |
| Shipping volume |           | 2.1             |      | 0.06           |        | 2.1             |      | 0.06           |

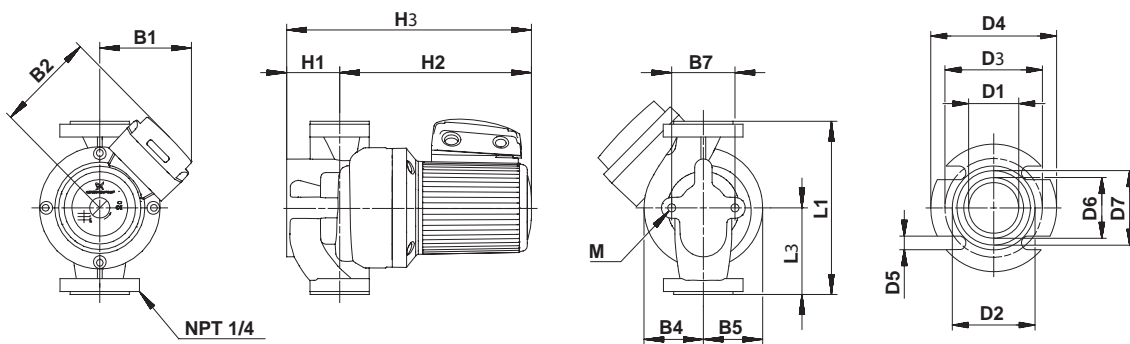

## Dimensions

|          | L1    | L3  | B1    | B2     | B4     | B5      | B7    | H1      | H2    | H3       | D1     | D2     | D3  | D4  | D5  | D6    | D7  | M   |
|----------|-------|-----|-------|--------|--------|---------|-------|---------|-------|----------|--------|--------|-----|-----|-----|-------|-----|-----|
| [Inches] | 9 7/8 | 5   | 5 1/4 | 5 9/16 | 3 9/16 | 2 15/16 | 4 3/4 | 2 15/16 | 9 7/8 | 12 13/16 | 2 1/16 | 4 3/16 | 5   | 6   | 5/8 | 3 2/4 | 4   |     |
| [mm]     | 250   | 127 | 133   | 141    | 91     | 75      | 120   | 75      | 251   | 326      | 53     | 106    | 127 | 152 | 16  | 89    | 101 | M12 |