

TM03 1457 2205

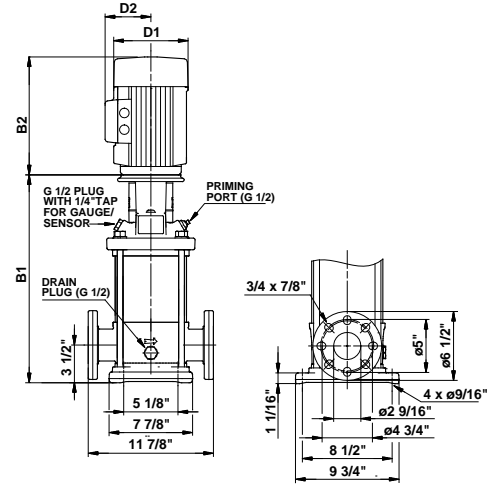

TM03 1459 2205

Pump type	Hp	Ph	PJE*	Dimensions					Ship Wt. [lbs]
				B1	B2	D1	D2	B1 + B2	
CRN(E) 20-1	3	3	*	20.63	12.55	7.19	5.72	33.18	156
CRN(E) 20-2	7.5	3	*	21.13	15.43	8.60	5.91	36.56	242
CRN(E) 20-3	10	3	*	22.71	15.51	10.28	8.05	38.22	251
CRN(E) 20-4	15	3	*	27.11	16.57	10.28	9.22	43.68	262
CRN 20-5	15	3	*	28.78	16.57	10.28	9.22	45.35	414
CRN 20-6	20	3	*	30.55	19.57	10.28	9.40	50.12	440
CRN 20-7	20	3	*	32.32	19.57	10.28	9.40	51.89	454
CRN 20-8	25	3	*	33.22	22.40	12.94	11.52	55.62	519

All pumps are three phase. All dimensions in inches unless otherwise noted.

\* PJE flanged pump B1 and B1+B2 dimension is one inch less than ANSI flanged pump and weight is approximately 9 lbs. less.

• Available