

Introduction to CRN MAGdrive

Grundfos CRN MAGdrive pumps operate according to a magnetic-drive system (patents pending) eliminating the need for shaft seals. The power from the motor is transmitted to the pump by magnetic force. Combined with a hermetically sealed liquid end, the pump is totally leak-free.

The pump incorporates a standard NEMA motor with keyway and deep-groove ball bearings.



GRA4445

Fig. 1 CRN MAGdrive pumps

The MAGdrive solution is available for these pumps:

Pump type	CRN pumps with magnetic drive										
	1s	1	3	5	10	15	20	32	45	64	90
CRN(E)	●	●	●	●	●	●	●	●*	●*	●*	●*

- Available.
- * Available up to 30 HP.

A soft starter is required on 25 and 30 HP motors (2 pole).

A soft starter is required on all 4-pole motors.

CRN MAGdrive features and benefits

- hermetically sealed drive system for 100 % leak-free pump operation
- special design and materials for low energy loss
- simple pump design for ease of service
- unique pump design for efficient cooling of the MAGdrive by means of the pumped liquid
- NEMA explosion proof motors optional. Class I, Group D and Class II, Group F&G. UL Listed and CSA Certified.

Applications

The CRN MAGdrive pump is suitable for wide selection of industrial applications such as:

- Aggressive or corrosive liquids**
Sulphuric acid, nitric acid, phosphoric acid, etc.
- Toxic liquids**
Trichloroethylene, chloroform, phenol, etc.
- Flammable liquids**
Petrol, jet fuels, LPG, alcohols, etc.
- Refrigerants**
Ammonia, synthetic chemicals, etc.

Design

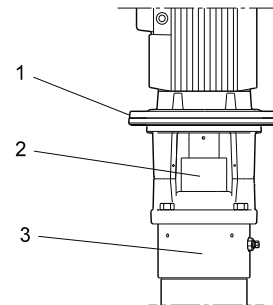

TM03 9149 3407

Fig. 2 MAGdrive system

Pos.	Designation	Materials
1	Motor stool	Cast iron. Stainless steel on request.
2	MAGdrive	See page 5
3	Pump head	Stainless steel (AISI 316).

The standard CRN MAGdrive pump elastomer is EPDM. The optional CRN MAGdrive pump elastomers are:

- FXM (Flouraz[®])
- FFKM (Kalrez[®])
- FKM (Viton[®])

Connections

These connections available for CRN MAGdrive pumps:

Connection type	CRN			
	1s, 1, 3, 5, 10, 15, 20	32, 45, 64, 90		
DIN, ANSI, JIS flange	●	●		
PJE	●	●		
FlexiClamp, union, oval flange, TriClamp	●			

- Available.

Construction

A magnetic field is generated by two magnets; the outer magnet is driven by the motor, and the inner magnet is connected to the pump. The shafts are not connected.

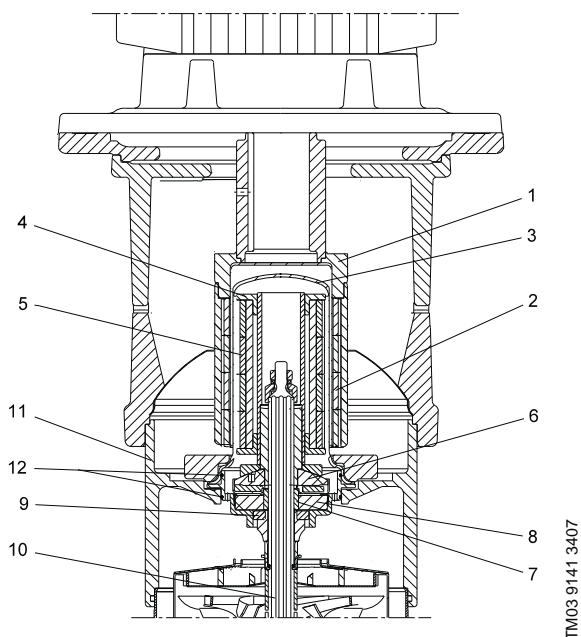

Fig. 3 Sectional drawing of MAGdrive system

Pos.	Designation	Material
1	Outer drive	AISI 304 SS
2	Outer magnets	NdFeB (neodymium)
3	Can	AISI 904L SS
4	Inner drive	AISI 316 SS
5	Inner magnets	NdFeB (neodymium)
6	Rotating thrust bearing	SiC-g (silicon carbide, carbon-filled)
7	Stationary thrust bearing	SiC-g (silicon carbide, carbon-filled)
8	Radial bearing	SiC (silicon carbide)
9	Upthrust bearing	Carbon-graphite-filled PTFE
10	Drive/pump shaft	CRN 1s-5 : AISI 316 SS CRN 10-20 : AISI 329 SS CRN 32-90 : SAF 2205
11	Pump head	CF 8M (cast equiv. of AISI 316 SS)
12	O-ring	EPDM, FKM, FXM, FFKM

Operating conditions

Maximum pressure
362 PSI

Temperature range
-4 °F to +248 °F

Viscosity range
0.25 to 100 Centipoise

Technical data

Motor range
0.50 HP to 30 HP

Dimensions
The height of the MAGdrive system typically makes the pump taller than a standard CRN pump.

Some CRN MAGdrive pumps will have a larger motor than the standard range.