

CRNE 3-HS

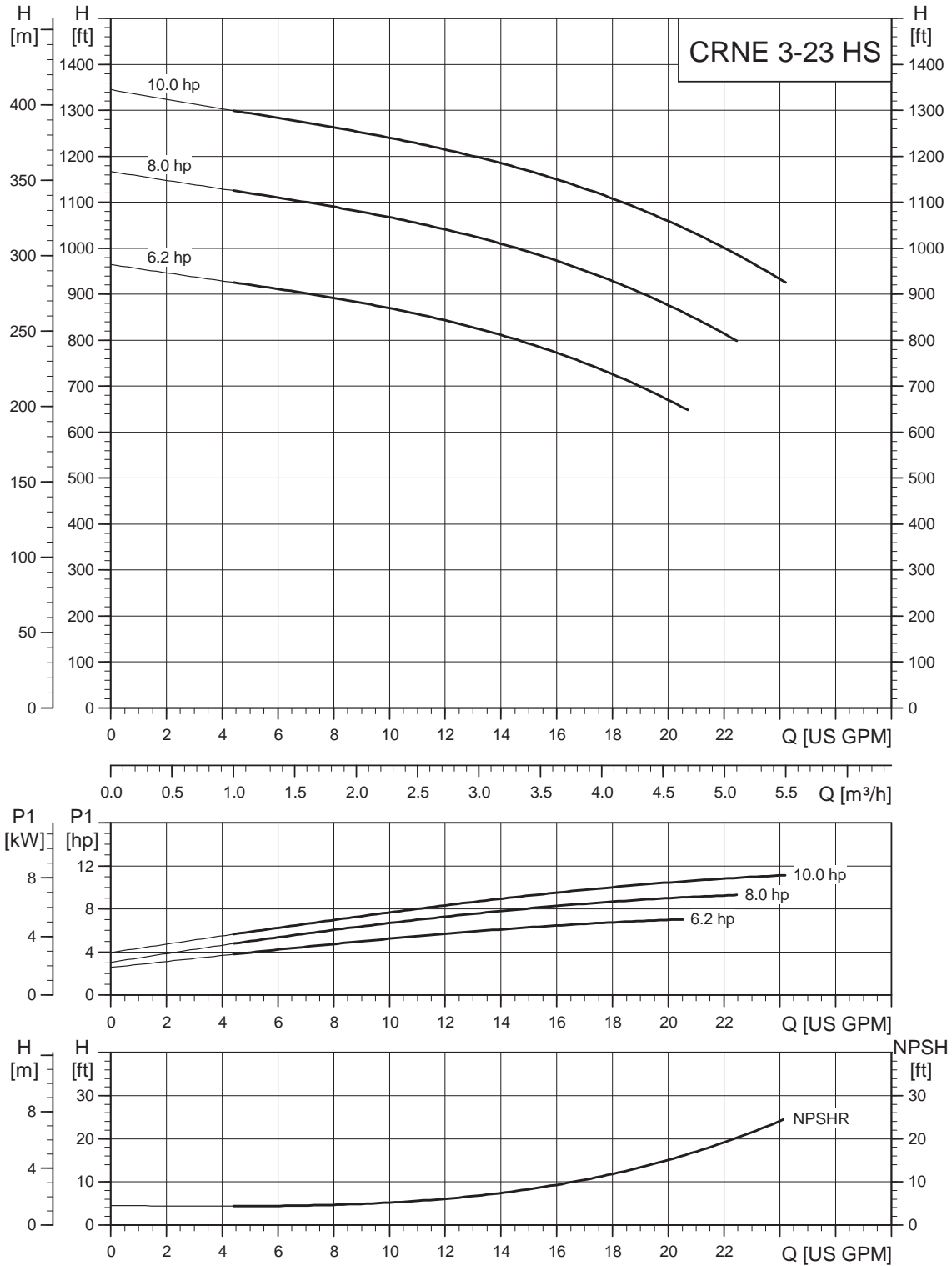

TM02 8309 2806

Dimensional sketch

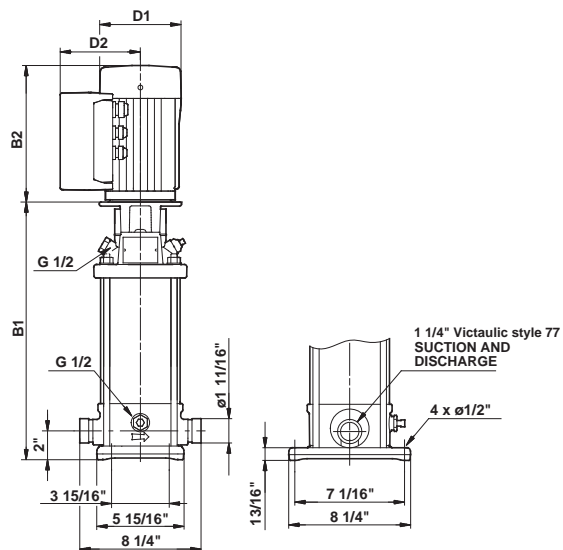

Dimensions and weights

Pump type	Hp	Ph	Voltage [V]	Frame size	Dimensions [in]				PJE ship wt. ¹ [lbs]
					PJE B1	TEFC D1	TEFC D2	PJE TEFC B1+B2	
CRNE 3-23 HS	6.2	3	460	112 CA	26.77	8.66	7.40	41.42	148
CRNE 3-23 HS	8.0	3	460	112 CB	26.77	8.66	7.40	42.16	157
CRNE 3-23 HS	10.0	3	460	112 DA	26.77	10.24	8.39	42.16	168