

CRN 20-SF

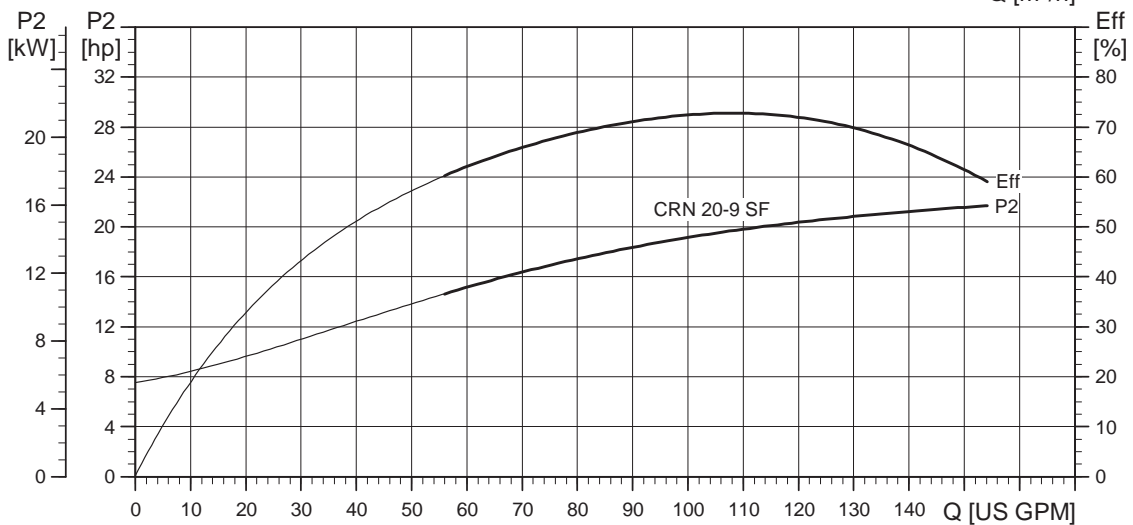

TM02 8313 2806

Dimensional sketches

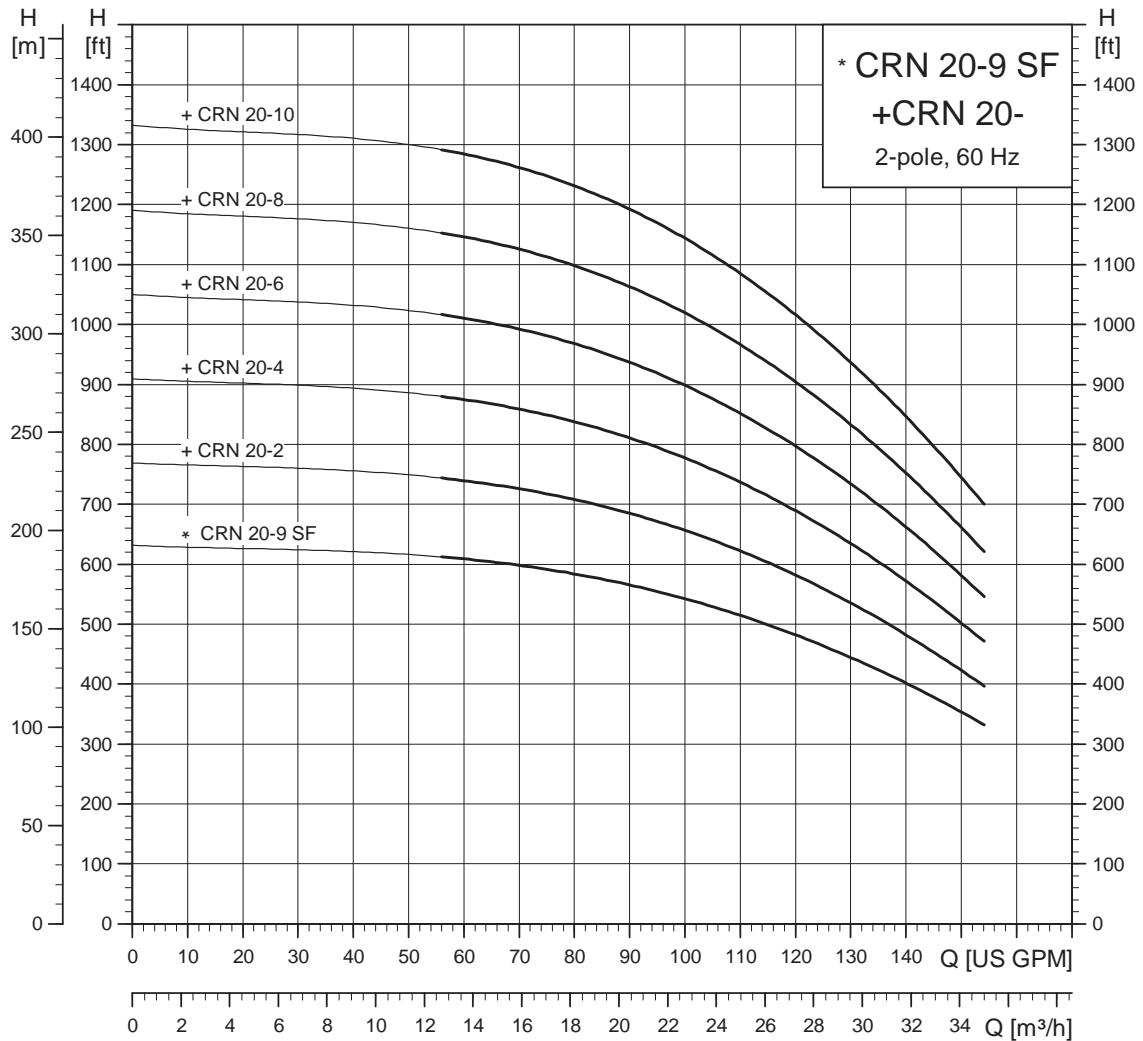
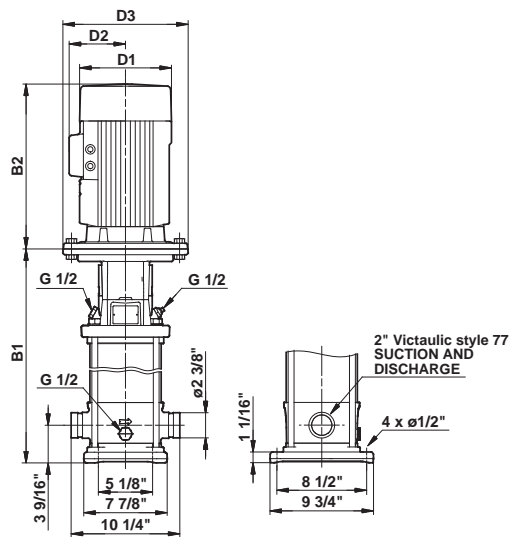

TM02 8850 1906

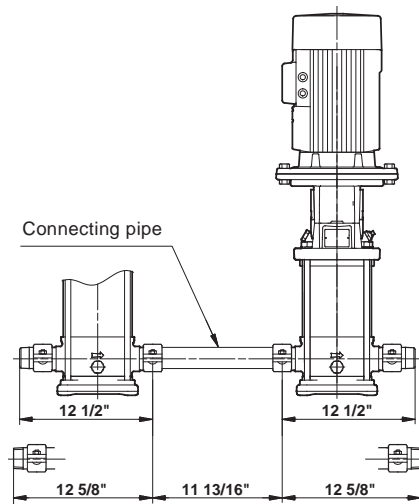

TM02 8851 0904

CRN feed pump/CRN SF high-pressure pump

CRN feed pump, connecting pipe and CRN SF high-pressure pump

Dimensions and weights

Pump type	Hp	Ph	Voltage [V]	Frame size	Dimensions							PJE ship wt. ¹ [lbs]
					PJE B1	TEFC D1	TEFC D2	PJE TEFC B1+B2	ODP D1	ODP B2	PJE ODP B1+B2	
CRN 20-2	5	1	208-230	182TC	17.13	10.62	7.46	32.65	-	-	-	187
		3	208-230/460		17.13	8.66	5.28	32.64	-	-	-	184
CRN 20-4	10	1	230	213TC	20.98	10.23	10.30	37.05	-	-	-	320
		3	208-230/460		20.98	8.66	5.28	36.49	-	-	-	196
CRN 20-6	15	3	208-230/460	254TC	27.05	10.22	8.67	43.63	10.62	7.33	43.36	385
CRN 20-8	20	3	230/460	254TC	30.59	10.22	8.67	47.17	11.50	8.92	50.28	424
CRN 20-10	25	3	230/460	284TSC	33.5	12.94	11.52	53.32	11.50	8.94	54.31	479
CRN 20-9 SF	25	3	460	160LB	34.92	12.36	8.03	55.20	-	-	-	486