

## CR, CRN 150

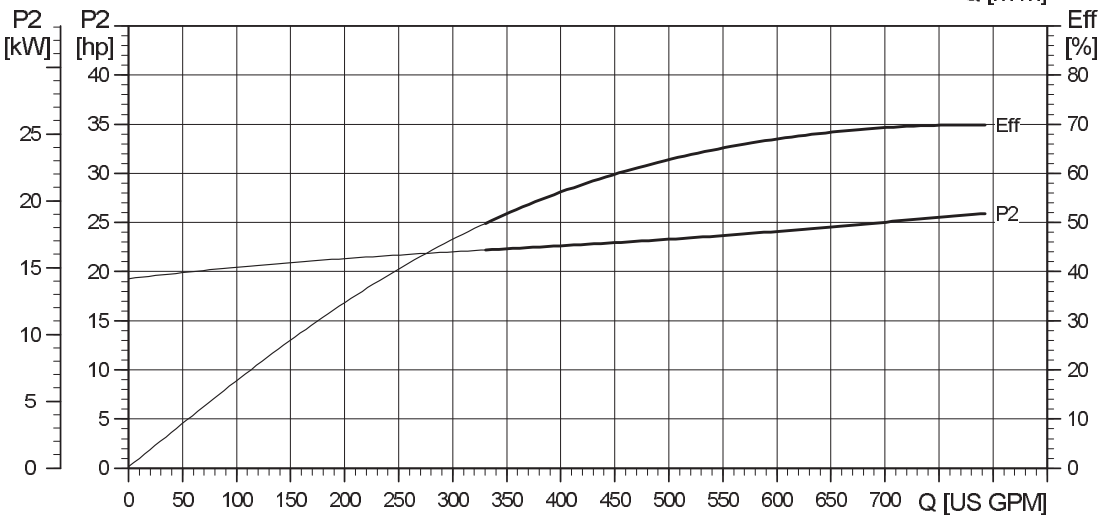

TM04 5615

## Dimensional sketches

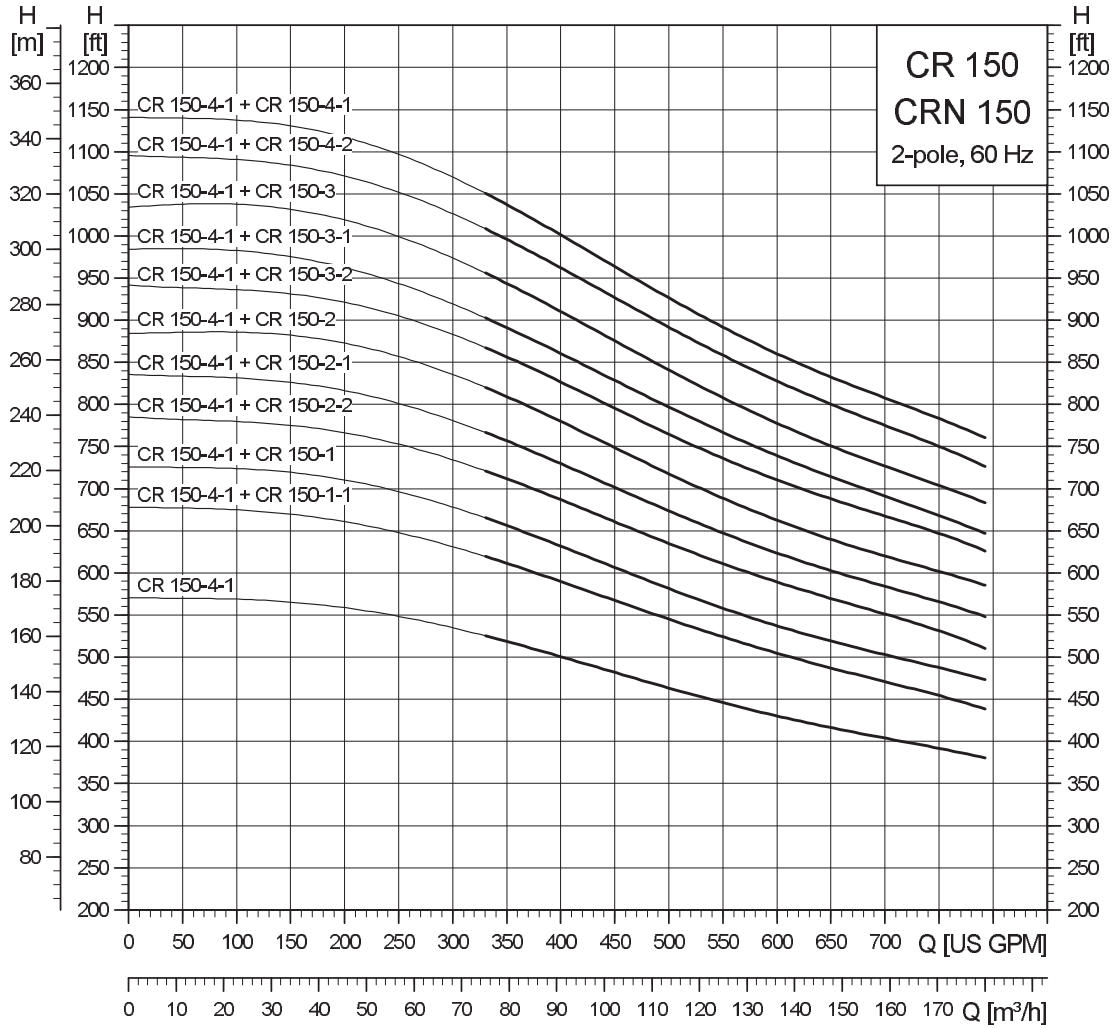
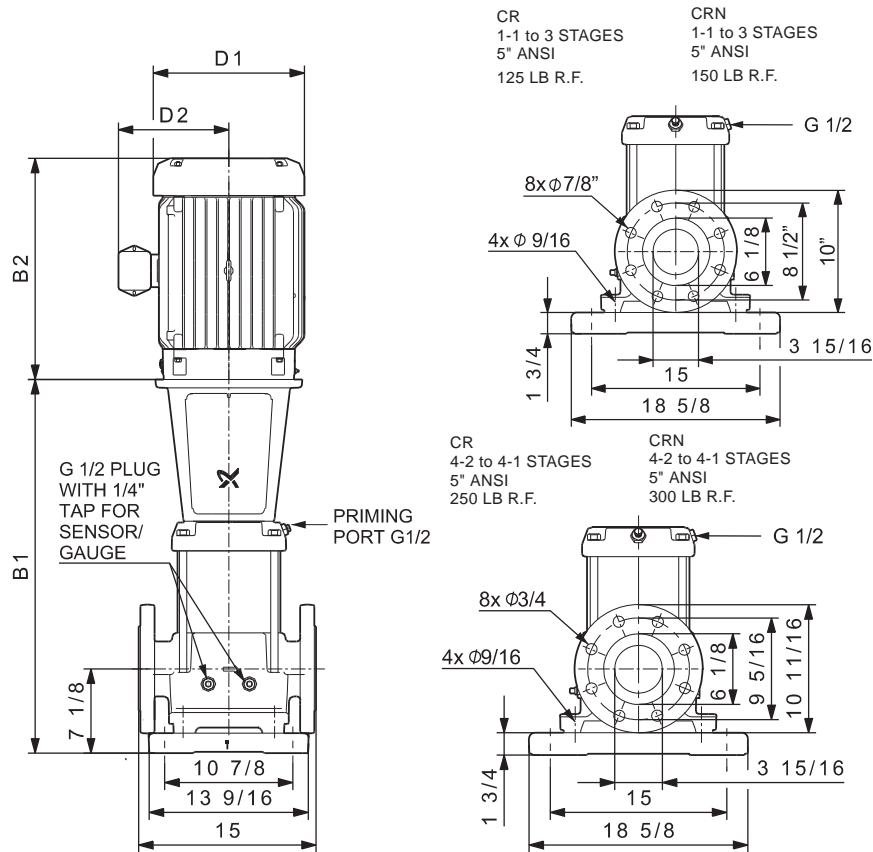

TM04 3178 3908

## Dimensions and weights

Pump Type	Hp	Ph	Voltage [V]	NEMA Frame Size	ANSI B1	TEFC D1	TEFC D2	ANSI TEFC B1+B2	ODP D1	ODP D2	ANSI ODPB1+B2	ANSI Ship wt. <sup>1</sup> [lbs.]
CR, CRN 150-1-1	25	3	230/460	284TSCZ	32.83	12.94	11.52	52.65	11.50	8.94	53.64	514
CR, CRN 150-1	30	3	230/460	284TSCZ	32.83	15.32	13.11	56.02	11.50	8.94	54.64	675
CR, CRN 150-2-2	40	3	230/460	284TSC	38.98	15.32	13.11	62.17	13.25	12.21	62.23	711
CR, CRN 150-2-1	50	3	230/460	326TSCZ	38.98	16.88	14.12	66.79	13.25	12.21	61.73	741
CR, CRN 150-2	60	3	230/460	364TSCZ	38.98	19.00	14.90	69.77	15.12	13.19	65.11	922
CR, CRN 150-3-2	75	3	230/460	365TSCZ	45.55	19.00	14.90	76.34	15.18	13.19	71.68	1184
CR, CRN 150-3-1	75	3	230/460	365TSCZ	45.55	19.00	14.90	76.34	15.18	13.19	71.68	1184
CR, CRN 150-3	100	3	230/460	405TSCZ	45.55	19.00	17.38	76.37	15.12	13.19	72.93	1222
CR, CRN 150-4-2	100	3	230/460	405TSCZ	51.69	19.00	17.38	82.51	15.12	13.19	79.07	1243
CR, CRN 150-4-1	100	3	230/460	405TSCZ	51.69	19.00	17.38	82.51	15.12	13.19	79.07	1243
CR, CRN 150-4-1	100	3	230/460	405TSCZ	51.69	19.00	17.38	82.51	15.12	13.19	79.07	1243