

### Introduction

This data booklet deals with CR-H and CRN-H horizontal end suction pumps as well as CRE-H and CRNE-H pumps.

### CR-H, CRN-H



TM04 3882

Fig. 1 CR-H pumps

CR-H, CRN-H pumps are horizontal end suction pumps typically mounted on baseplates. The end suction design enables the pump to be installed horizontally in traditional, end suction design piping where the pump has an axial suction port and a radial center line discharge port. This design allows “back pull-out” capability so that most models can be serviced without removing the volute from the pipe system.

Grundfos CR-H, CRN-H pump range includes various pump sizes and various numbers of stages to provide the flow and the pressure required.

CR-H, CRN-H pumps are suitable for a variety of applications from pumping of potable water to pumping of chemicals. The pumps are therefore used in a wide variety of pumping systems where the performance and material of the pump meet specific demands.

The CR-H, CRN-H pumps consist of three main components: the motor, the pump unit, and the baseplate.

The pump unit consists of optimized hydraulics, various flange connections, a pump head, an end suction volute, and various other parts.

CR-H, CRN-H pumps are available in various material versions according to the pumped liquid.

CR-H, CRN-H pumps can be selected that meet ASME B73.1 dimensional standards for suction and discharge piping as well as many of the baseplate dimensional standards. **CR-H, CRN-H pumps do not fully comply with the ASME B73.1 specification.**

There is also a full range of CR-H, CRN-H pumps with standard Grundfos connection sizes that are optimized to give greater performance and efficiency.

### CRE-H, CRNE-H



TM04 4177 0909

Fig. 1 CRE-H pumps

CRE-H, CRNE-H pumps are built on the basis of CR-H, CRN-H pumps. CRE-H, CRNE-H pumps belong to the so-called E-pump family and are referred to as E-pumps. The difference between the CR-H, CRN-H and the CRE-H, CRNE-H pump range is the motor. CRE-H, CRNE-H pumps are fitted with an E-motor with built-in frequency control. The CRE-H, CRNE-H pump has a Grundfos MLE motor.

Frequency control enables continuously variable control of motor speed, which makes it possible to set the pump to operation at any duty point. The aim of continuously variable control of the motor speed is to adjust the performance to a given requirement.

CRE-H, CRNE-H pumps are available with an attached pressure sensor connected to a frequency control.

The pump materials are the same as those of the CR-H, CRN-H.

### Selecting a CRE-H, CRNE-H pump

Select a CRE-H, CRNE-H pump if:

- controlled operation is required, i.e. consumption fluctuates.
- constant pressure is required.
- communication with the pump is required.

Adaptation of performance through frequency-controlled speed control offers obvious advantages:

- energy savings
- increased comfort
- control and monitoring of the pump performance.

See pages 10 - 12 for more information about E-pumps.

## Performance range

### CR-H, CRN-H

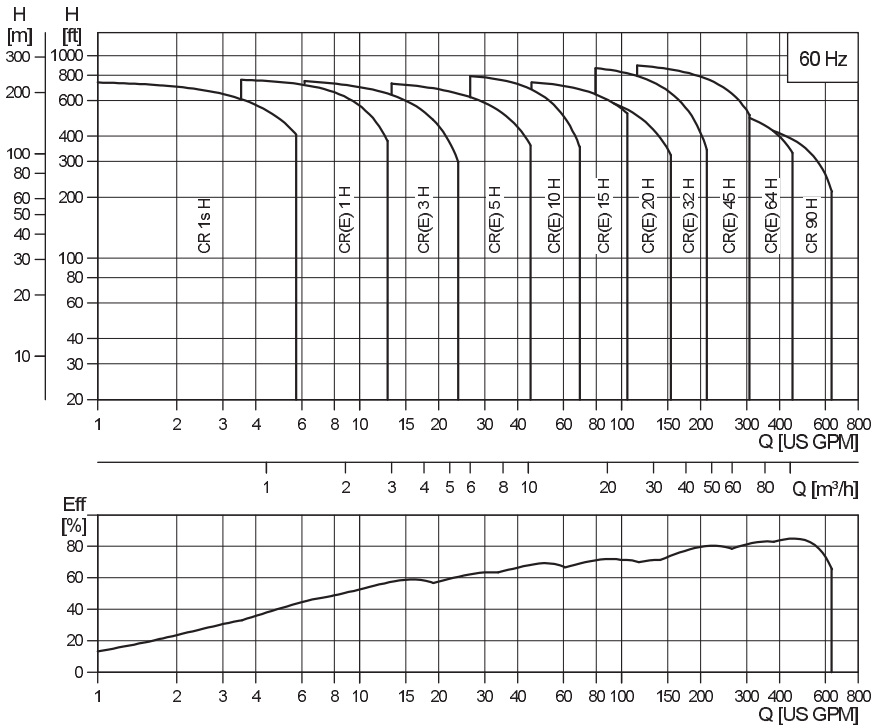

TM04 4552

### CRE-H, CRNE-H

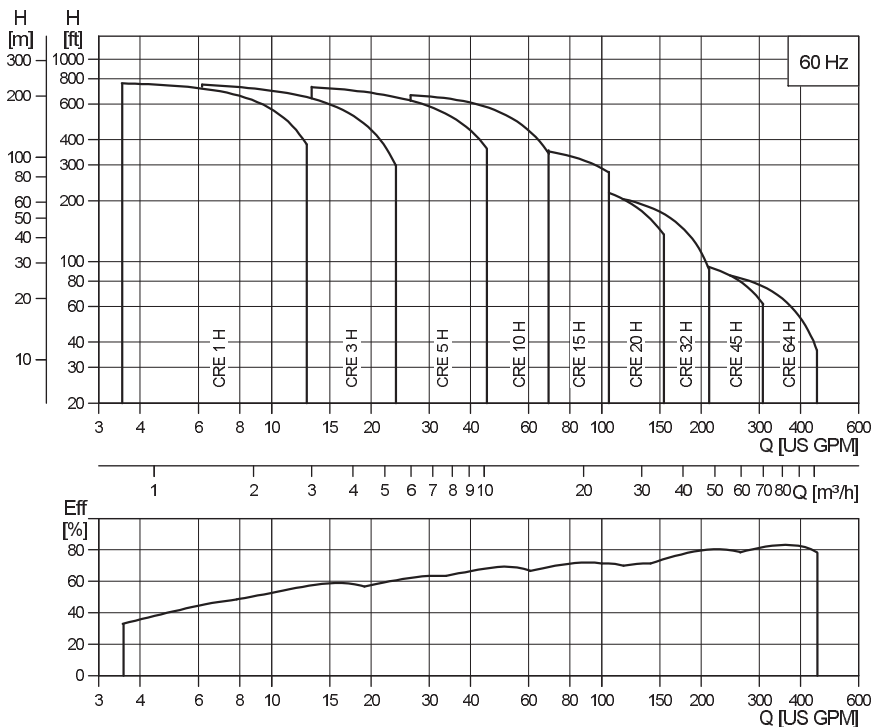

TM04 9018

## Applications

Application	CR-H	CRN-H	CRE-H, CRNE-H
<b>Water supply</b>			
Filtration and transfer at waterworks	●	○	●
Distribution from waterworks	●	○	●
Pressure boosting in mains	●	○	●
Pressure boosting in high-rise buildings, hotels, etc.	●	○	●
Pressure boosting for industrial water supply	●	○	●
<b>Industry</b>			
<b>Pressure boosting...</b>			
process water systems	●	●	●
washing and cleaning systems	●	●	●
vehicle washing tunnels	●	○	●
fire fighting systems	●		
<b>Liquid transfer...</b>			
cooling and air-conditioning systems (refrigerants)	●	○	●
boiler feed and condensate systems	●	○	●
machine tools (cooling lubricants)	●	●	●
aquafarming	●	○	
<b>Special transfer duties...</b>			
oils and alcohols	●	●	●
acids and alkalis		●	
glycol and coolants	●	●	●
<b>Water treatment</b>			
Ultrafiltration systems		●	●
Reverse osmosis systems		●	●
Softening, ionizing, demineralizing systems		●	●
Distillation systems		●	●
Separators	●	●	●
Swimming pools		●	●
<b>Irrigation</b>			
Field irrigation (flooding)	●	○	
Sprinkler irrigation	●	○	●
Drip-feed irrigation	●	○	

● Recommended version.

○ Alternative version.

## Product range

Range	CR, CRE 1s H	CR, CRE 1 H	CR, CRE 3 H	CR, CRE 5 H	CR, CRE 10 H	CR, CRE 15 H	CR, CRE 20 H	CR, CRE 32 H	CR, CRE 45 H	CR, CRE 64 H	CR 90 H
Nominal flow rate [US GPM]	4.5	8.5	15	30	55	95	110	140	220	340	440
Temperature range [°F]						-4 to +250		-22 to +250			
Temperature range [°F] — on request						-40 to +356		-40 to +356			
Max. working pressure [psi]	360	360	360	360	360	360	360	435	435	435	435
Max. pump efficiency [%]	35	49	59	64	70	72	72	73	80	82	85
<b>CR-H pumps</b>											
CR: Flow range [US GPM]	0.5 - 5.7	1 - 12.8	1.5 - 23.8	3 - 45	5.5 - 70	9.5 - 125	11 - 155	14 - 210	22 - 310	34 - 450	44 - 630
CR: Max. pump pressure (H[ft])	745	785	785	780	810	760	675	935	930	590	570
CR: Motor power [Hp]	0.33 - 2.0	0.33 - 3.0	0.33 - 5.0	0.75 - 7.5	0.75 - 15	2.0 - 25	3.0 - 25	3.0 - 50	7.5 - 60	7.5 - 60	15 - 60
<b>CRE-H pumps</b>											
CRE: Flow range [US GPM]	0 - 5.7	0 - 12.8	0 - 23.8	0 - 45	0 - 70	0 - 125	0 - 155	0 - 210	0 - 310	0 - 450	-
CRE: Max. pump pressure (H[ft])	745	785	785	780	670	385	270	225	120	100	-
CRE: Motor power [Hp]	0.33 - 2.0	0.33 - 3.0	0.33 - 5.0	0.75 - 7.5	0.75 - 10	2.0 - 10	3.0 - 10	3.0 - 10	7.5	7.5	-
<b>Version</b>											
CR-H, CRE-H versions: Cast iron and stainless steel AISI 304	•	•	•	•	•	•	•	•	•	•	•
CRN-H, CRNE-H versions: Stainless steel AISI 316	•	•	•	•	•	•	•	•	•	•	•
<b>CR-H, CRE-H pipe connection</b>											
ANSI connection type	GA	GA	GA	GA	G22*	G22*	G22*	G22*	G33*	G44*	G44*
ANSI flange class [lb]	125/ 250	125/ 250	125/ 250	125/ 250	125/ 250	125/ 250	125/ 250	125/ 250	125/ 250	125/ 250	125/ 250
<b>CRN-H, CRNE-H pipe connection</b>											
ANSI connection type	GA	GA	GA	GA	G22*	G22*	G22*	G22*	G33*	G44*	G44*
ANSI flange class [lb]	150/ 300	150/ 300	150/ 300	150/ 300	150/ 300	150/ 300	150/ 300	150/ 300	150/ 300	150/ 300	150/ 300
<b>Pipe connection - inlet x discharge x impeller size reference</b>											
GA	ANSI 1.5" x 1" x 6", 1.5" x 1" x 8"	•	•	•	•	•	•	•	•		
G05	ANSI 2" x 1" x 10"				•	•	•	•			
GB	ANSI 3" x 1.5" x 6", 3" x 1.5" x 8"					•	•	•	•		
GC	ANSI 3" x 2" x 6"							•	•	•	
G10	ANSI 3" x 2" x 6"							•	•	•	
G50	ANSI 3" x 1.5" x 8", 3" x 1.5" x 10"							•	•	•	
G60	ANSI 3" x 2" x 8", 3" x 2" x 10"							•	•	•	•
G20	ANSI 3" x 1.5" x 13"								•	•	•
G30	ANSI 3" x 2" x 13"								•	•	•
G70	ANSI 4" x 3" x 8", 4" x 3" x 10"									•	•
G40	ANSI 4" x 3" x 10", 4" x 3" x 13"									•	•
G22	ANSI 2" x 2"				•	•	•	•			
G33	ANSI 3" x 3"							•	•		
G44	ANSI 4" x 4"									•	•

• Available

\* There are a variety of flange size options available for this size CR-H (see list above). Selection should be based on replacement size or choose listed size for new installations.

## Pump

The CR-H, CRN-H pump is a non-self-priming, horizontal, end suction, multistage centrifugal pump with enclosed impellers. The pumps are available with a Grundfos standard motor (CR-H, CRN-H pumps) or a frequency-controlled motor (CRE-H, CRNE-H pumps).

The pump consists of a volute and a pump head. The chamber stack and the outer sleeve are secured between the pump head and the volute by means of staybolts. The volute has an end suction port and vertical centerline discharge port.

All pumps are equipped with a maintenance-free mechanical shaft seal of the cartridge type.

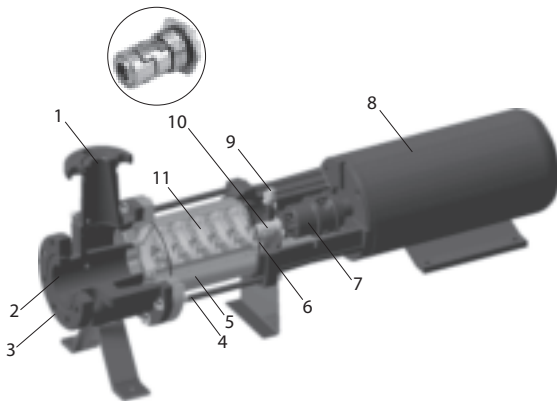

Fig. 2 CR-H pump

### CR-H components

Pos.	Designation	Pos.	Designation
1	Discharge	7	Coupling
2	Suction	8	Motor
3	Flange	9	Priming plug
4	Staybolts	10	Shaft seal
5	Outer sleeve	11	Impellers
6	O-ring		

## Motor

### Grundfos standard motors - ML and Baldor® motors

CR-H, CRN-H pumps are fitted with a Grundfos specified motor. The motors are all heavy-duty 2-pole, NEMA C-face motors. Three-phase motors greater than .75 hp are Premium efficient at minimum.

### Frequency-controlled motors - MLE motors

CRE-H, CRNE-H pumps are fitted with a totally enclosed, fan-cooled, 2-pole frequency-controlled motor with integrated variable frequency drive.

From 0.5 Hp to 1.5 Hp Grundfos offers pumps fitted with single-phase MLE motors (1 x 208-230 V). From 1.0 Hp to 10 Hp Grundfos offers pumps fitted with three-phase MLE motors (3 x 460-480 V). From 1.5 Hp to 7.5 Hp Grundfos offers pumps fitted with three-phase MLE motors (3 x 208-230 V).

## Electrical data and approvals

<b>Mounting designation</b>	NEMA
<b>Insulation class</b>	F & B
<b>Efficiency class</b>	<ul style="list-style-type: none"> <li>• <b>Standard efficiency</b> - single phase</li> <li>• <b>Premium efficiency</b> - three phase Grundfos ML and Baldor motors</li> </ul>
<b>Enclosure class</b>	TEFC - Totally Enclosed Fan Cooled (Grundfos standard) ODP - Open Drip Proof - on request
<b>60 Hz Standard voltages</b>	1 x 115/208-230 V 3 x 208-230/460 V 3 x 575 V

<b>Approvals</b>	Baldor	ML/MLE	CE

## Optional motors

The Grundfos standard range of motors covers a wide variety of application demands. However, for special applications or operating conditions, custom-built motor solutions can be provided.

For special applications or operating conditions, Grundfos offers custom-built motors such as:

- explosion proof motors
- motors with anti-condensation heating unit
- low-noise motors
- energy efficient and premium efficiency motors
- motors with thermal protection.

## Motor protection

Single-phase Grundfos specified motors up to 7.5 hp have a built-in thermal overload switch.

Three-phase motors **must** be connected to a motor starter in accordance with local regulations.

### MLE motors

CRE-H, CRNE-H pumps require no external motor protection. The MLE motor incorporates thermal protection against slow overloading and blocking.

## Terminal box positions

As standard the terminal box is mounted as shown in fig. 3.

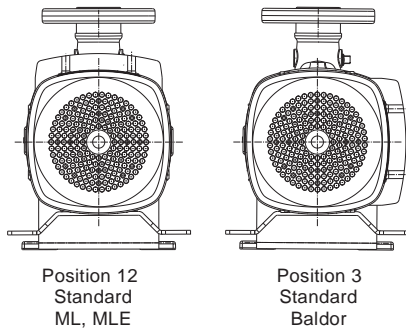

Fig. 3 Terminal box positions

TM02 18 05 2001

## Ambient temperature

If the ambient temperature exceeds the maximum temperature limits of the motor or the pump is installed at an altitude exceeding the altitude values in the chart below, the motor must not be fully loaded due to the risk of overheating.

Overheating may result from excessive ambient temperatures or the low density and consequently low cooling effect of the air at high altitudes. In such cases, it may be necessary to use a motor with a higher rated output ( $P_2$ ).

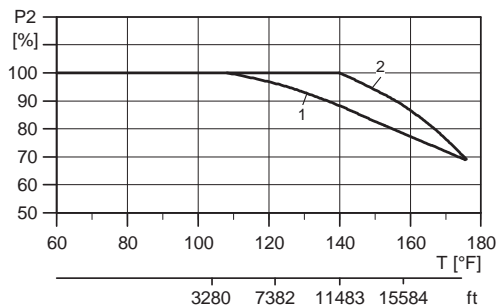

Fig. 4 Relationship between motor output ( $P_2$ ) and ambient temperature/altitude

TM03 4272 2006

Legend

Pos.	Description
1	NEMA energy efficient motors (EPAct)
2	NEMA Premium efficiency motors

**Example:** From fig. 4 it appears that  $P_2$  must be reduced to 88 % when a pump with a NEMA Premium efficiency, ML motor is installed 15,584 feet above sea level. At an ambient temperature of 167 °F,  $P_2$  of an energy efficient motor must be reduced to 74 % of rated output.

## Viscosity

The pumping of liquids with densities or kinematic viscosities higher than those of water will cause a considerable pressure drop, a drop in the hydraulic performance and a rise in the power consumption.

In such situations the pump should be equipped with a larger motor. For selection you may utilize Grundfos WinCAPS/WebCAPS. If in doubt, contact Grundfos.

## Examples of E-pump applications

CRE-H, CRNE-H pumps are the ideal solution in a number of applications characterized by a need for variable flow at constant pressure. The pumps are suited for water supply systems and pressure boosting, but also industrial applications.

Depending on the nature of the application, the pumps offer energy-savings, increased comfort or improved processing.

### E-pumps in the service of industry

Industry uses a large number of pumps in many different applications. Demands on pumps in terms of pump performance and mode of operation make speed control a must in many applications.

Below are mentioned some of the applications in which E-pumps are often used.

#### Constant pressure

- Water supply
- washing and cleaning systems
- distribution from waterworks
- humidifying systems
- water treatment systems
- process boosting systems, etc.

**Example:** Within industrial water supply, E-pumps with integrated pressure sensors are used to ensure a constant pressure in the piping network. From the sensor, the E-pump receives inputs about changes of pressure as a result of changes in the consumption. The E-pump responds to the input by adjusting the flow until the pressure is equalized. As a result, the constant pressure is stabilized once more on the basis of a preset setpoint.

#### Constant temperature

- Air-conditioning systems at industrial plants
- industrial cooling systems
- industrial freezing systems
- casting and molding tools, etc.

**Example:** In industrial freezing systems, E-pumps with temperature sensors increase comfort and lower operating costs compared with pumps without temperature sensors.

An E-pump continuously adapts its performance to the changing demands reflected in the differences in temperature of the liquid circulating in the freezing system. Thus, the lower the demand for cooling, the smaller the quantity of liquid circulated in the system and vice versa.

#### Constant flow or level

- Steam boiler systems
- condensate systems
- sprinkler irrigation systems
- chemical industry, etc.

**Example:** In a steam boiler, it is important to be able to monitor and control pump operation to maintain a constant level of water in the boiler.

By using an E-pump with level sensor mounted in the boiler, it is possible to maintain a constant water level. A constant water level ensures optimum and cost-efficient operation as a result of a stable steam production.

#### Dosing

- Chemical industry (i.e. control of pH-values)
- petrochemical industry
- degreasing systems
- bleaching systems, etc.

**Example:** In the petrochemical industry, E-pumps with pressure sensors are used as dosing pumps. The E-pumps help to ensure that the correct mixture ratio is achieved when more liquids are combined.

E-pumps functioning as dosing pumps improve processing and offer energy-savings.

#### E-pumps in commercial building services

Commercial building services use E-pumps to maintain a constant pressure or a constant temperature based on a variable flow.

E-pumps are used in applications such as:

#### Constant pressure

- Water supply in high-rise buildings i.e. office buildings, hotels, etc.

**Example:** E-pumps with pressure sensors are used for water supply in high-rise buildings to ensure a constant pressure even at the highest draw-off point. As the consumption pattern and thus the pressure changes during the day, the E-pump continuously adapts its performance until the pressure is equalized.

#### Constant temperature

- Air-conditioning systems in hotels, schools, etc.
- building cooling systems, etc.

**Example:** E-pumps are an excellent solution in buildings where constant temperature is essential. E-pumps keep the temperature constant in air-conditioned, high-rise glass buildings, irrespective of the seasonal fluctuations of the out-door temperature and various heat impacts inside the building.