

CR, CRE 64 H G40/G70

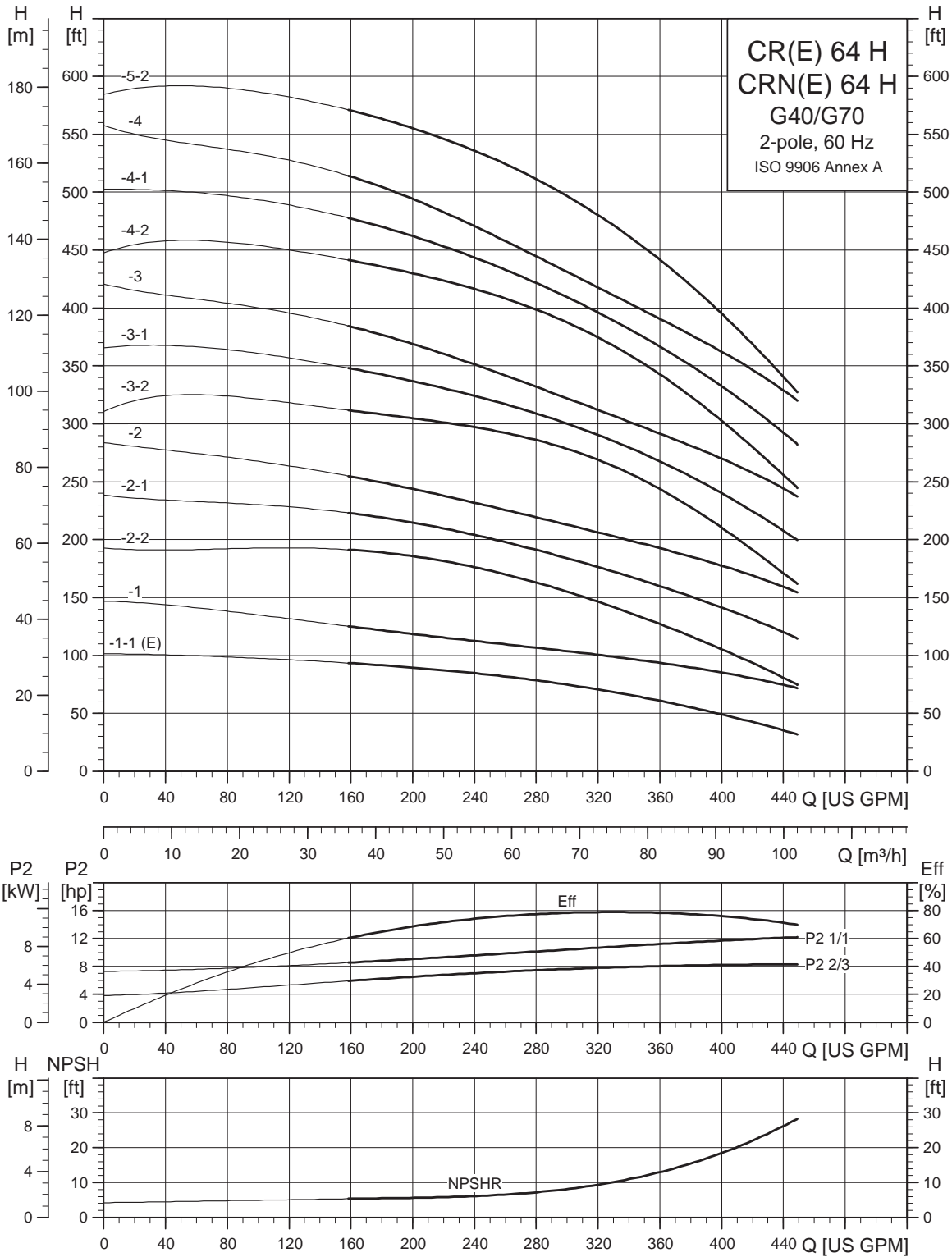

TM04 6301 4610

Dimensional sketches G40 (4" x 3" x 10", 4" x 3" x 13")

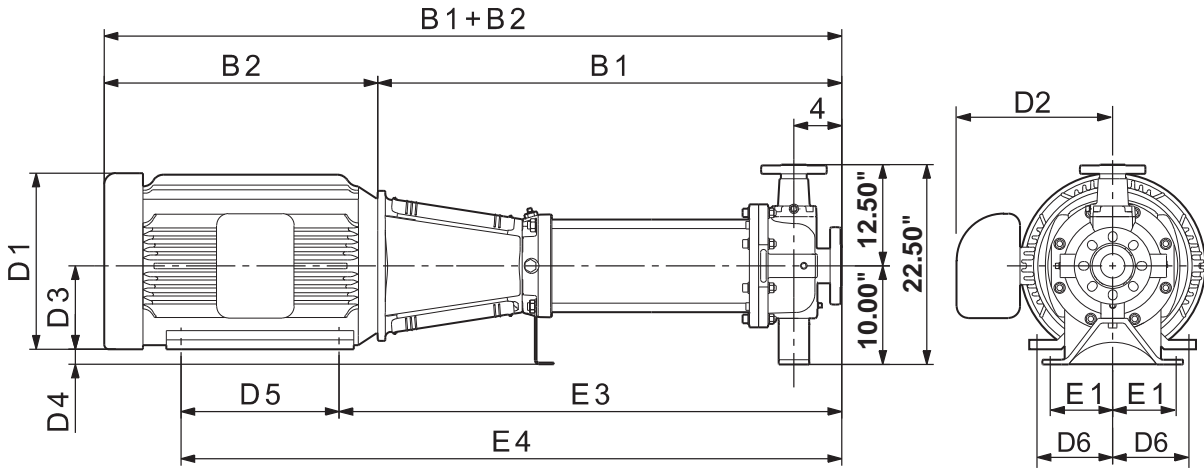

TM04 4872 0510

Dimensions and weights G40 (4" x 3" x 10", 4" x 3" x 13")

Pump type	Power [hp]	Ph	Dimensions [inches]										Ship. weight [lbs]	Dimensions [inches]			Ship. weight [lbs]				
			TEFC											ODP				MLE			
			B1	B1+B2	E1	E3	E4	D1	D2	D3	D4	D5		D6	D1	D2		B1+B2	D1	D2	B1+B2
CR(N)(E) 64-1-1 H	10	1	27.13	42.88	4.88	30.38	35.88	11.50	10.38	5.25	4.75	5.50	4.25	365	—	—	—	—	—	—	
		3	27.13	42.63	4.88	30.38	35.88	8.75	5.38	5.25	4.75	5.50	4.25	349	—	—	—	8.75	7.50	42.63	363
CR(N)64-1 H	15	3	27.13	47.38	4.88	31.13	39.38	12.63	9.50	6.25	3.75	8.25	5.00	431	10.75	6.88	45.00	—	—	—	—
CR(N) 64-2-2 H	20	3	30.38	50.13	4.88	34.38	42.63	12.75	10.13	6.25	3.75	8.25	5.00	441	11.50	9.00	48.00	—	—	—	—
CR(N) 64-2-1 H	20	3	30.38	50.13	4.88	34.38	42.63	12.75	10.13	6.25	3.75	8.25	5.00	455	11.50	9.00	48.00	—	—	—	—
CR(N) 64-2 H	25	3	30.38	51.75	4.88	34.88	44.38	12.75	12.13	7.00	3.00	9.50	5.50	535	11.50	11.38	49.13	—	—	—	—
CR(N) 64-3-2 H	30	3	33.63	55.00	4.88	38.13	49.13	12.75	12.13	7.00	3.00	11.00	5.50	706	11.50	11.38	53.88	—	—	—	—
CR(N) 64-3-1 H	40	3	33.63	55.00	4.88	38.13	49.13	15.63	12.13	7.00	3.00	11.00	5.50	720	11.50	11.38	54.50	—	—	—	—
CR(N) 64-3 H	40	3	33.63	55.00	4.88	38.13	49.13	15.63	12.13	7.00	3.00	11.00	5.50	720	11.50	11.38	54.50	—	—	—	—
CR(N) 64-4-2 H	40	3	36.88	58.25	4.88	41.38	52.38	15.63	12.13	7.00	3.00	11.00	5.50	731	11.50	11.38	57.75	—	—	—	—
CR(N) 64-4-1 H	50	3	36.88	62.00	4.88	41.88	53.88	16.50	14.63	8.00	2.00	12.00	6.25	761	13.38	12.25	58.75	—	—	—	—
CR(N) 64-4 H	50	3	36.88	62.00	4.88	41.88	53.88	16.50	14.63	8.00	2.00	12.00	6.25	761	13.38	12.25	58.75	—	—	—	—
CR(N) 64-5-2 H	60	3	40.13	67.25	4.88	45.75	57.00	17.00	14.63	9.00	1.00	11.25	7.00	959	15.13	11.63	63.88	—	—	—	—

Note: Terminal box is on top of motor on 3-phase up to 10 hp. All other motors have terminal box on the side. Reference D2 dimension. Weights are based on pump with TEFC motor.

Dimensional sketches G70 (4" x 3" x 8", 4" x 3" x 10")

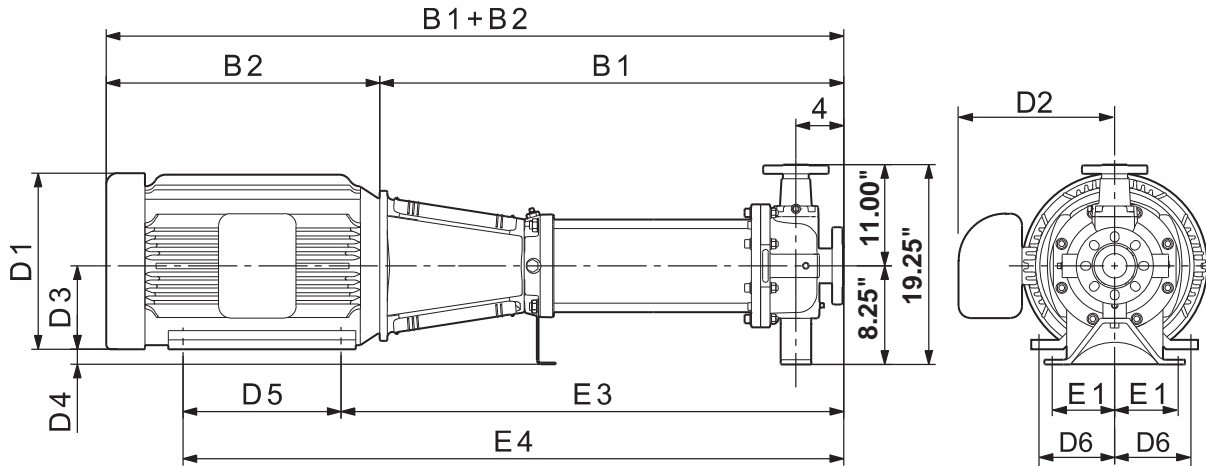

TM04 4872 0510

Dimensions and weights G70 (4" x 3" x 8", 4" x 3" x 10")

Pump type	Power [hp]	Ph	Dimensions [inches]											Ship. weight [lbs]	Dimensions [inches]			Ship. weight [lbs]			
			TEFC												ODP				MLE		
			B1	B1+B2	E1	E3	E4	D1	D2	D3	D4	D5	D6		D1	D2	B1+B2		D1	D2	B1+B2
CR(N) (E) 64-1-1 H	10	1	27.13	42.88	4.88	30.38	35.88	11.50	10.38	5.25	3.00	5.50	4.25	338	—	—	—	—	—	—	—
		3	27.13	42.63	4.88	30.38	35.88	8.75	5.38	5.25	3.00	5.50	4.25	322	—	—	—	8.75	7.50	42.63	336
CR(N) 64-1 H	15	3	27.13	47.38	4.88	31.13	39.38	12.63	9.50	6.25	2.00	8.25	5.00	404	10.75	6.88	45.00	—	—	—	—
CR(N) 64-2-2 H	20	3	30.38	50.13	4.88	34.38	42.63	12.75	10.13	6.25	2.00	8.25	5.00	414	11.50	9.00	48.00	—	—	—	—
CR(N) 64-2-1 H	20	3	30.38	50.13	4.88	34.38	42.63	12.75	10.13	6.25	2.00	8.25	5.00	428	11.50	9.00	48.00	—	—	—	—
CR(N) 64-2 H	25	3	30.38	51.75	4.88	34.88	44.38	12.75	12.13	7.00	1.25	9.50	5.50	508	11.50	11.38	49.13	—	—	—	—
CR(N) 64-3-2 H	30	3	33.63	55.00	4.88	38.13	49.13	12.75	12.13	7.00	1.25	11.00	5.50	679	11.50	11.38	53.88	—	—	—	—
CR(N) 64-3-1 H	40	3	33.63	55.00	4.88	38.13	49.13	15.63	12.13	7.00	1.25	11.00	5.50	694	11.50	11.38	54.50	—	—	—	—
CR(N) 64-3 H	40	3	33.63	55.00	4.88	38.13	49.13	15.63	12.13	7.00	1.25	11.00	5.50	694	11.50	11.38	54.50	—	—	—	—
CR(N) 64-4-2 H	40	3	36.88	58.25	4.88	41.38	52.38	15.63	12.13	7.00	1.25	11.00	5.50	731	11.50	11.38	57.75	—	—	—	—
CR(N) 64-4-1 H	50	3	36.88	62.00	4.88	41.88	53.88	16.50	14.63	8.00	0.25	12.00	6.25	761	13.38	12.25	58.75	—	—	—	—
CR(N) 64-4 H	50	3	36.88	62.00	4.88	41.88	53.88	16.50	14.63	8.00	0.25	12.00	6.25	761	13.38	12.25	58.75	—	—	—	—
CR(N) 64-5-2 H	60	3	40.13	67.25	4.88	45.75	57.00	17.00	14.63	9.00	-0.75	11.25	7.00	959	15.13	11.63	63.88	—	—	—	—

Note: Terminal box is on top of motor on 3-phase up to 10 hp. All other motors have terminal box on the side. Reference D2 dimension. Weights are based on pump with TEFC motor.