

## CR, CRE 45 H G33

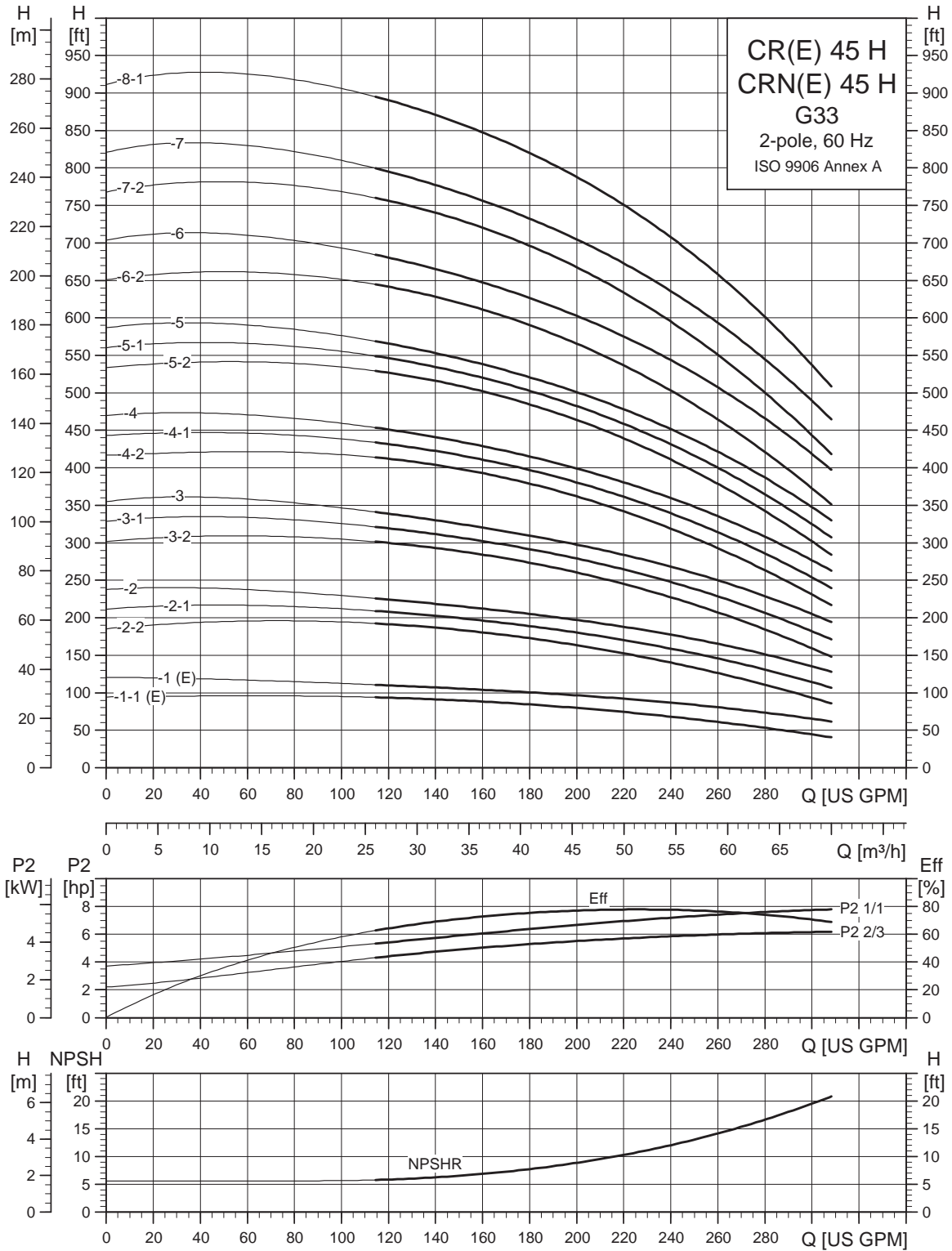

TMD4 6298 4610

## Dimensional sketches G33 (3" x 3")

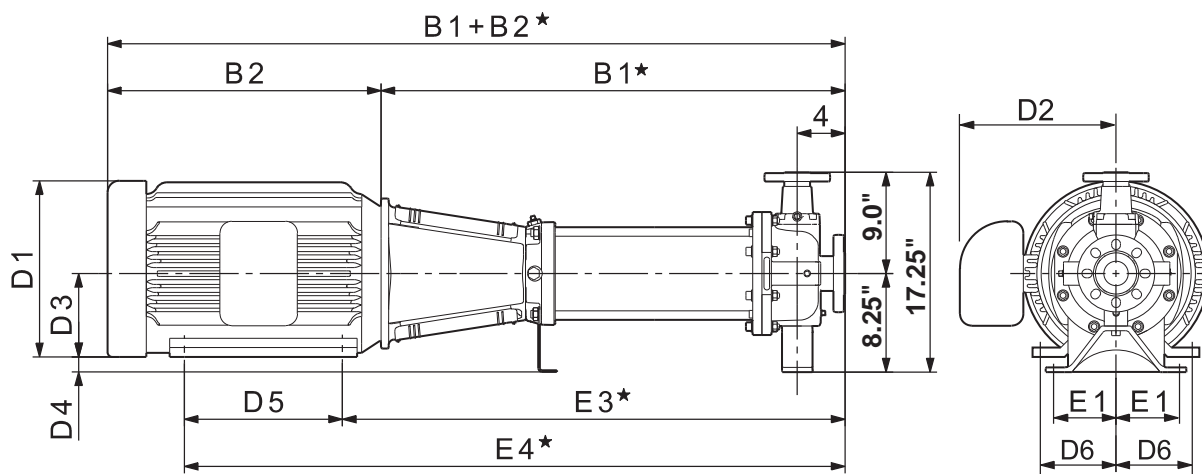

TM04 4872 0310

## Dimensions and weights G33 (3" x 3")

Pump type	Power [hp]	Ph	Dimensions [inches]												Ship. weight [lbs]	Dimensions [inches]			Ship. weight [lbs]			
			TEFC													ODP				MLE		
			B1*	B1+B2*	E1	E3*	E4*	D1	D2	D3	D4	D5	D6	D1		D2	B1+B2*	D1		D2	B1+B2*	
CR(N)(E) 45-1-1 H	7.5	1	25.88	41.13	4.88	29.13	34.63	10.25	7.63	5.25	3.00	5.50	4.25	275	—	—	—	—	—	—	—	
		3	25.88	41.38	4.88	29.13	34.63	8.75	5.38	5.25	3.00	5.50	4.25	259	—	—	—	8.75	7.50	41.38	273	
CR(N)(E) 45-1 H	10	1	25.88	41.63	4.88	29.13	34.63	11.50	10.38	5.25	3.00	5.50	4.25	275	—	—	—	—	—	—	—	
		3	25.88	41.38	4.88	29.13	34.63	8.75	5.38	5.25	3.00	5.50	4.25	259	—	—	—	8.75	7.50	41.38	273	
CR(N) 45-2-2 H	15	3	29.00	49.25	4.88	33.00	41.25	12.63	9.50	6.25	2.00	8.25	5.00	349	10.75	6.88	46.88	—	—	—	—	
CR(N) 45-2-1 H	15	3	29.00	49.25	4.88	33.00	41.25	12.63	9.50	6.25	2.00	8.25	5.00	349	10.75	6.88	46.88	—	—	—	—	
CR(N) 45-2 H	15	3	29.00	49.25	4.88	33.00	41.25	12.63	9.50	6.25	2.00	8.25	5.00	349	10.75	6.88	46.88	—	—	—	—	
CR(N) 45-3-2 H	20	3	32.13	51.88	4.88	36.13	44.38	12.75	10.13	6.25	2.00	8.25	5.00	391	11.50	9.00	49.88	—	—	—	—	
CR(N) 45-3-1 H	25	3	32.13	53.63	4.88	36.63	46.13	12.75	12.13	7.00	1.25	9.50	5.50	471	11.50	11.38	51.00	—	—	—	—	
CR(N) 45-3 H	25	3	32.13	53.63	4.88	36.63	46.13	12.75	12.13	7.00	1.25	9.50	5.50	471	11.50	11.38	51.00	—	—	—	—	
CR(N) 45-4-2 H	30	3	35.25	56.75	4.88	39.75	50.75	12.75	12.13	7.00	1.25	11.00	5.50	709	11.50	11.38	55.63	—	—	—	—	
CR(N) 45-4-1 H	30	3	35.25	56.75	4.88	39.75	50.75	12.75	12.13	7.00	1.25	11.00	5.50	709	11.50	11.38	55.63	—	—	—	—	
CR(N) 45-4 H	30	3	35.25	56.75	4.88	39.75	50.75	12.75	12.13	7.00	1.25	11.00	5.50	709	11.50	11.38	55.63	—	—	—	—	
CR(N) 45-5-2 H	40	3	38.50	59.88	4.88	43.00	54.00	15.63	12.13	7.00	1.25	11.00	5.50	732	11.50	11.38	59.38	—	—	—	—	
CR(N) 45-5-1 H	40	3	38.50	59.88	4.88	43.00	54.00	15.63	12.13	7.00	1.25	11.00	5.50	732	11.50	11.38	59.38	—	—	—	—	
CR(N) 45-5 H	40	3	38.50	59.88	4.88	43.00	54.00	15.63	12.13	7.00	1.25	11.00	5.50	732	11.50	11.38	59.38	—	—	—	—	
CR(N) 45-6-2 H	50	3	41.63	66.75	4.88	46.63	58.63	16.50	14.63	8.00	0.25	12.00	6.25	777	13.38	12.25	63.50	—	—	—	—	
CR(N) 45-6 H	50	3	41.63	66.75	4.88	46.63	58.63	16.50	14.63	8.00	0.25	12.00	6.25	777	13.38	12.25	63.50	—	—	—	—	
CR(N) 45-7-2 H	50	3	44.75	69.88	4.88	49.75	61.75	16.50	14.63	8.00	0.25	12.00	6.25	796	13.38	12.25	66.75	—	—	—	—	
CR(N) 45-7 H	60	3	44.75	71.88	4.88	50.38	61.63	17.00	14.63	9.00	-0.75	11.25	7.00	975	15.13	11.63	68.63	—	—	—	—	
CR(N) 45-8-1 H	60	3	47.88	75.13	4.88	53.50	64.75	17.00	14.63	9.00	-0.75	11.25	7.00	985	15.13	11.63	71.75	—	—	—	—	

Note: Terminal box is on top of motor on 3-phase up to 10 hp. All other motors have terminal box on the side. Reference D2 dimension. Weights are based on pump with TEFC motor.

★ Add 0.67 inches for CRN-H dimensions.