

## CR, CRN 150

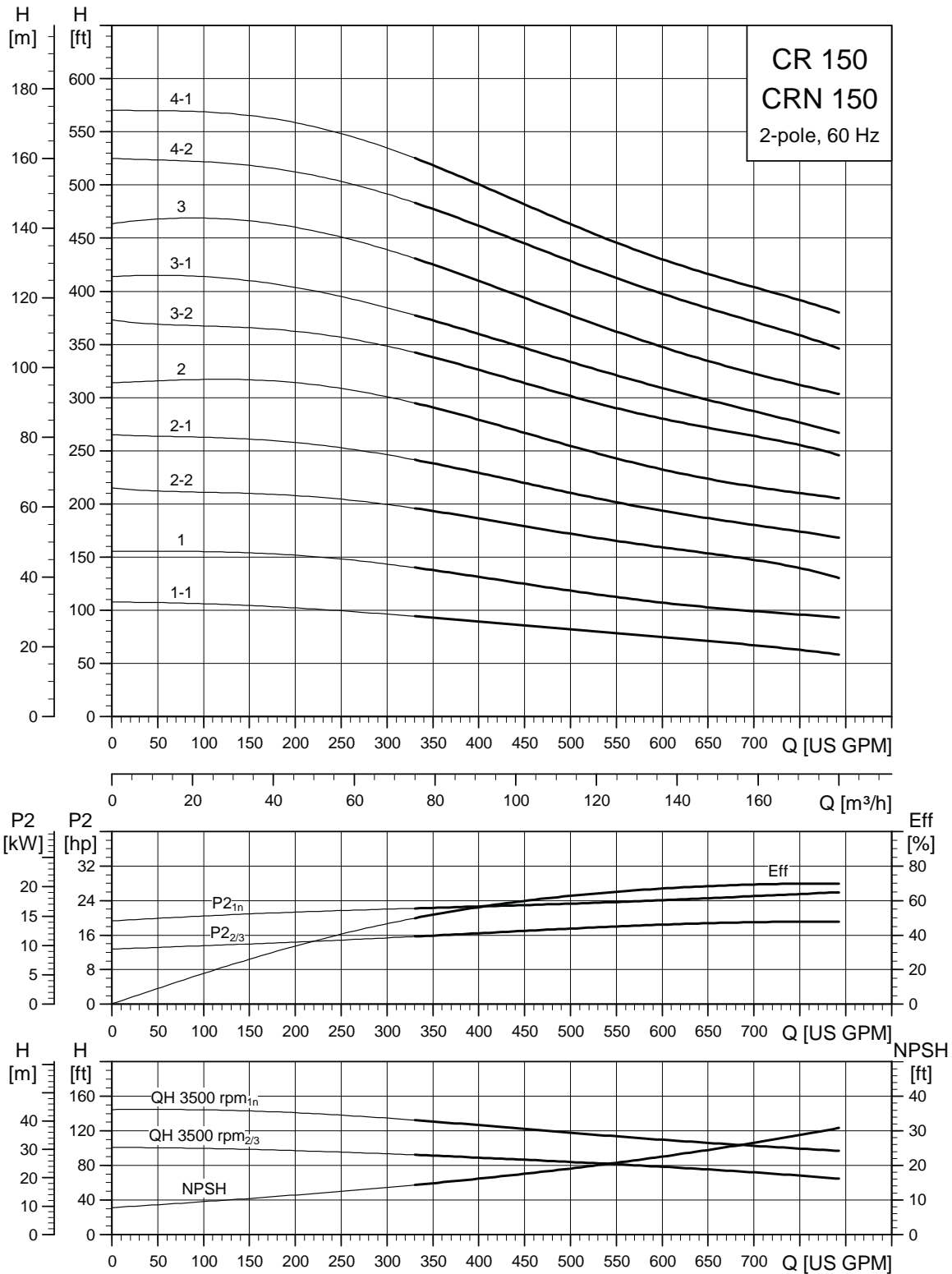

TM03 9193 0209

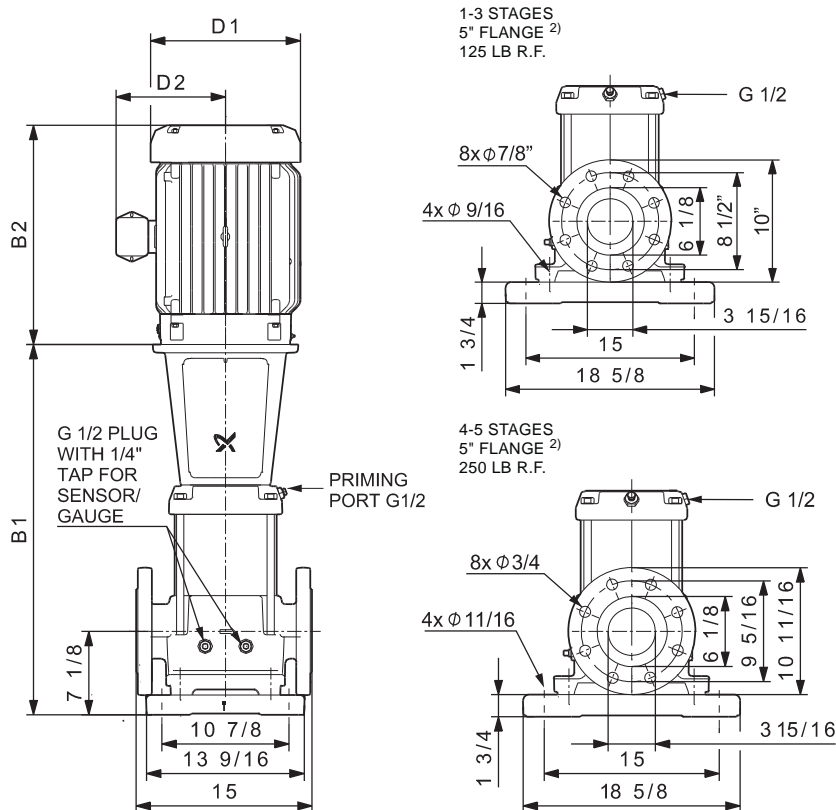

TM04 9632 4810

Pump type	P2 [hp]	Ph.	Dimensions [inch]									Dimensions [inch]			
			B1	TEFC			ODP			Ship Wt. <sup>1)</sup> [lbs.]	MLE			Ship Wt. [lbs.]	
				D1	D2	B1+B2	D1	D2	B1+B2		D1	D2	B1+B2		
CR 150-1-1	25	3	32.83	12.94	11.52	52.65	11.50	8.94	53.64	507	-	-	-	-	
CR 150-1	30	3	32.83	15.32	13.11	56.02	11.50	8.94	54.64	669	-	-	-	-	
CR 150-2-2	40	3	38.98	15.32	13.11	62.17	13.25	12.21	62.23	705	-	-	-	-	
CR 150-2-1	50	3	38.98	16.88	14.12	66.79	13.25	12.21	61.73	735	-	-	-	-	
CR 150-2	60	3	38.98	19.00	14.90	69.77	15.12	13.19	65.11	915	-	-	-	-	
CR 150-3-2	75	3	45.55	19.00	14.90	76.34	15.18	13.19	71.68	1178	-	-	-	-	
CR 150-3-1	75	3	45.55	19.00	14.90	76.34	15.18	13.19	71.68	1178	-	-	-	-	
CR 150-3	100	3	45.55	19.00	17.38	76.37	15.12	13.19	72.93	1215	-	-	-	-	
CR 150-4-2	100	3	51.69	19.00	17.38	82.51	15.12	13.19	79.07	1234	-	-	-	-	
CR 150-4-1	100	3	51.69	19.00	17.38	82.51	15.12	13.19	79.07	1234	-	-	-	-	

<sup>1)</sup> Weights are based on pump with TEFC motor (see price list for individual weights).

<sup>2)</sup> CR 5" flange is not manufactured to ANSI specification. Gasket contact surface is approximately 0.25". CR 6" ANSI flange adapter is manufactured to ANSI B16.5 specification.

All dimensions in inches unless otherwise noted.

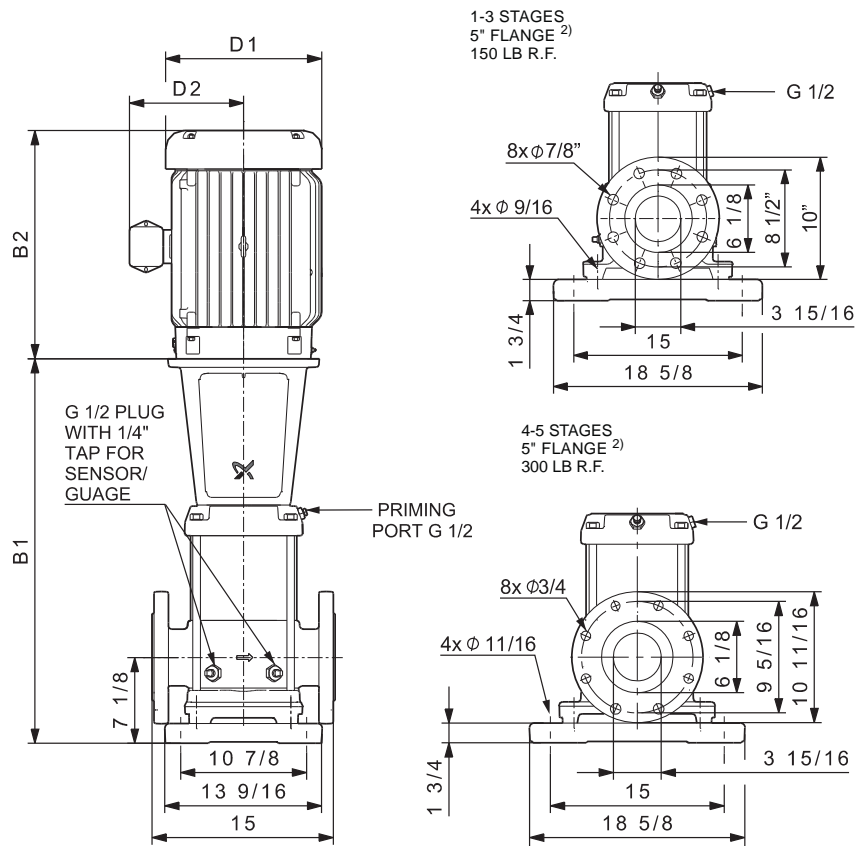

Pump type	P2 [hp]	Ph.	Dimensions [inch]									Dimensions [inch]			
			B1	TEFC			ODP			Ship Wt. <sup>1)</sup> [lbs.]	MLE			Ship Wt. [lbs.]	
				D1	D2	B1+B2	D1	D2	B1+B2		D1	D2	B1+B2		
CRN 150-1-1	25	3	32 83	12.94	11.52	52.65	11.50	8.94	53.64	514	-	-	-	-	
CRN 150-1	30	3	32 83	15.32	13.11	56.02	11.50	8.94	54.64	675	-	-	-	-	
CRN 150-2-2	40	3	38 98	15.32	13.11	62.17	13.25	12.21	62.23	711	-	-	-	-	
CRN 150-2-1	50	3	38 98	16.88	14.12	66.79	13.25	12.21	61.73	741	-	-	-	-	
CRN 150-2	60	3	38 98	19.00	14.90	69.77	15.12	13.19	65.11	922	-	-	-	-	
CRN 150-3-2	75	3	45 55	19.00	14.90	76.34	15.18	13.19	71.68	1184	-	-	-	-	
CRN 150-3-1	75	3	45 55	19.00	14.90	76.34	15.18	13.19	71.68	1184	-	-	-	-	
CRN 150-3	100	3	45 55	19.00	17.38	76.37	15.12	27.38	72.93	1222	-	-	-	-	
CRN 150-4-2	100	3	51 69	19.00	17.38	82.51	15.12	27.38	79.07	1243	-	-	-	-	
CRN 150-4-1	100	3	51 69	19.00	17.38	82.51	15.12	27.38	79.07	1243	-	-	-	-	

<sup>1)</sup> Weights are based on pump with TEFC motor (see price list for individual weights).

<sup>2)</sup> CR 5" flange is not manufactured to ANSI specification. Gasket contact surface is approximately 0.25". CR 6" ANSI flange adapter is manufactured to ANSI B16.5 specification.

All dimensions in inches unless otherwise noted.