

# Performance curves/ Technical data

CR 1s, CRI 1s, CRN 1s

## CR, CRI, CRN 1s

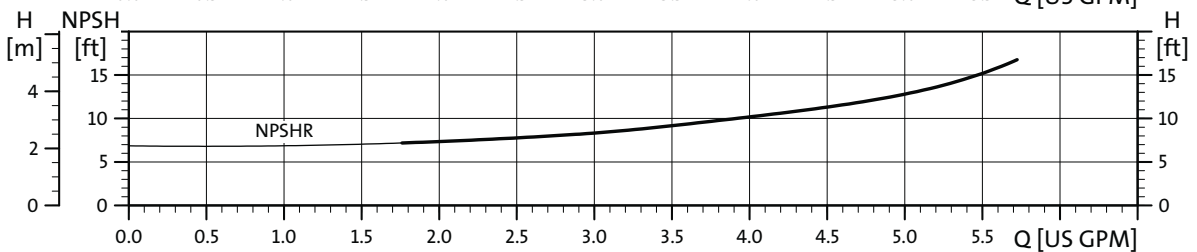
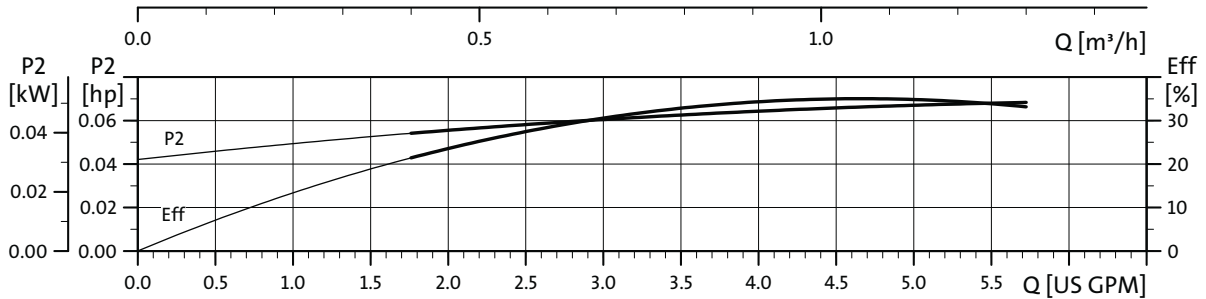
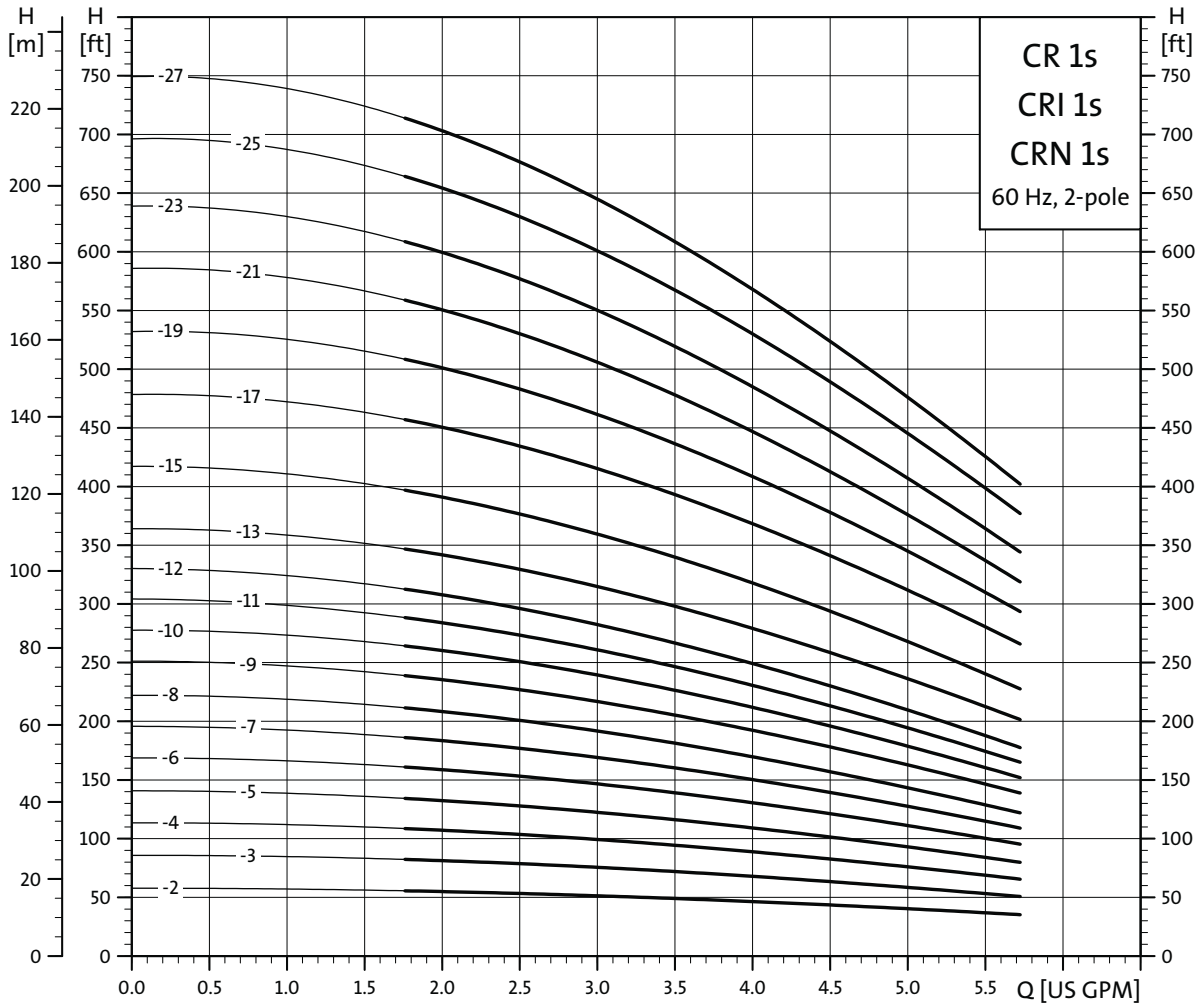

TM02 5741 1303

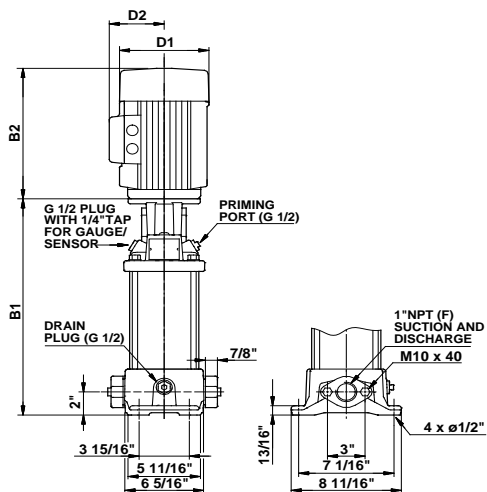

TM03 1450 2205

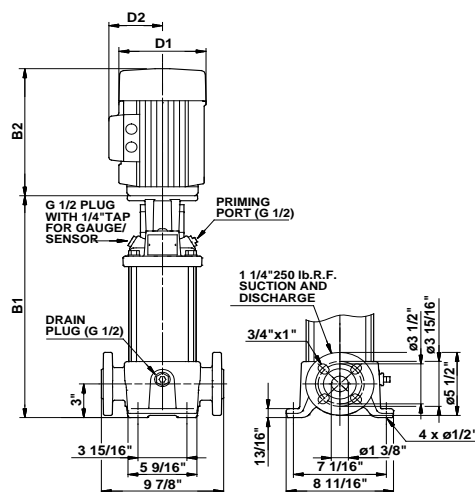

TM03 1451 2205

Pump type	P2 [hp]	Ph.	Oval*	ANSI dimensions [inch]				Ship Wt. [lbs.]
				B1	TEFC			
					D1	D2	B1+B2	
CR 1s-2	1/3	1	•	11.97	6.19	5.18	21.26	69
		3	•	11.97	5.55	4.57	19.41	67
CR 1s-3	1/3	1	•	11.97	6.19	5.18	21.26	69
		3	•	11.97	5.55	4.57	19.41	67
CR 1s-4	1/3	1	•	12.68	6.19	5.18	21.97	70
		3	•	12.68	5.55	4.57	20.12	68
CR 1s-5	1/3	1	•	13.39	6.19	5.18	22.68	71
		3	•	13.39	5.55	4.57	20.83	69
CR 1s-6	1/2	1	•	14.09	6.19	5.18	23.38	75
		3	•	14.09	5.55	4.57	21.53	70
CR 1s-7	1/2	1	•	14.80	6.19	5.18	24.09	76
		3	•	14.80	5.55	4.57	22.24	71
CR 1s-8	1/2	1	•	15.51	6.19	5.18	24.80	77
		3	•	15.51	5.55	4.57	22.95	72
CR 1s-9	3/4	1	•	16.22	6.19	5.18	26.13	82
		3	•	16.22	5.55	4.57	23.66	73
CR 1s-10	3/4	1	•	16.93	6.19	5.18	26.84	83
		3	•	16.93	5.55	4.57	24.37	74
CR 1s-11	3/4	1	•	17.64	6.19	5.18	27.55	84
		3	•	17.64	5.55	4.57	25.08	75
CR 1s-12	3/4	1	•	18.35	6.19	5.18	28.26	85
		3	•	18.35	5.55	4.57	25.79	76
CR 1s-13	1	1	•	19.06	7.19	5.73	30.25	101
		3	•	19.06	5.55	4.57	26.50	77
CR 1s-15	1	1	•	20.47	7.19	5.73	31.66	103
		3	•	20.47	5.55	4.57	27.91	78
CR 1s-17	1 1/2	1	•	21.89	7.19	5.73	33.57	107
		3	•	21.89	5.55	4.57	30.51	84
CR 1s-19	1 1/2	1	-	23.31	7.19	5.73	34.99	109
		3	-	23.31	5.55	4.57	31.93	86
CR 1s-21	1 1/2	1	-	24.72	7.19	5.73	36.40	111
		3	-	24.72	5.55	4.57	33.34	88
CR 1s-23	1 1/2	1	-	26.14	7.19	5.73	37.82	113
		3	-	26.14	5.55	4.57	34.76	90
CR 1s-25	2	1	-	27.56	7.19	5.73	40.12	126
		3	-	27.56	7.01	4.33	38.78	116
CR 1s-27	2	1	-	28.98	7.19	5.73	41.54	127
		3	-	28.98	7.01	4.33	40.20	118

All dimensions in inches unless otherwise noted.

\*Oval flanged pump B1 and B1+B2 dimension is one inch less than ANSI flanged pump and weight is approximately 9 lbs. less.

• Available

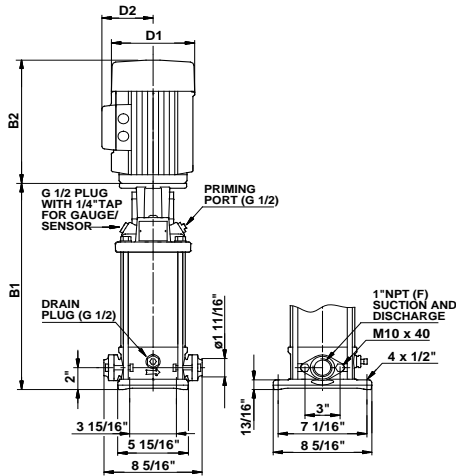

TM03 1452 2205

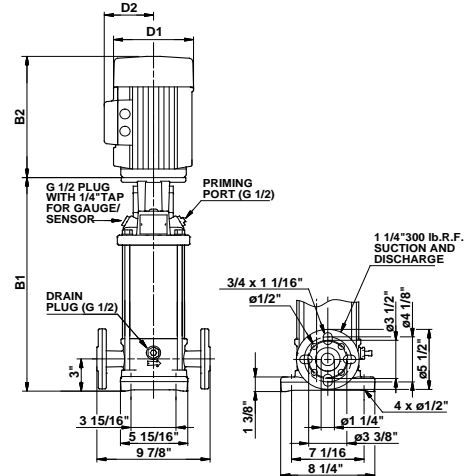

TM03 1453 2205

Pump type	P2 [hp]	Ph.	Oval*	ANSI dimensions [inch]				Ship Wt. [lbs.]
				B1	TEFC			
					D1	D2	B1+B2	
CRI 1s-2	1/3	1	•	12.09	6.19	5.18	21.38	64
		3	•	12.09	5.55	4.57	19.53	62
CRI 1s-3	1/3	1	•	12.09	6.19	5.18	21.38	64
		3	•	12.09	5.55	4.57	19.53	62
CRI 1s-4	1/3	1	•	12.80	6.19	5.18	22.09	65
		3	•	12.80	5.55	4.57	20.24	63
CRI 1s-5	1/3	1	•	13.50	6.19	5.18	22.79	66
		3	•	13.50	5.55	4.57	20.94	64
CRI 1s-6	1/2	1	•	14.21	6.19	5.18	23.50	70
		3	•	14.21	5.55	4.57	21.65	65
CRI 1s-7	1/2	1	•	14.92	6.19	5.18	24.21	71
		3	•	14.92	5.55	4.57	22.36	65
CRI 1s-8	1/2	1	•	15.63	6.19	5.18	24.92	72
		3	•	15.63	5.55	4.57	23.07	66
CRI 1s-9	3/4	1	•	16.34	6.19	5.18	26.25	77
		3	•	16.34	5.55	4.57	23.78	68
CRI 1s-10	3/4	1	•	17.05	6.19	5.18	26.96	78
		3	•	17.05	5.55	4.57	24.49	69
CRI 1s-11	3/4	1	•	17.76	6.19	5.18	27.67	79
		3	•	17.76	5.55	4.57	25.20	70
CRI 1s-12	3/4	1	•	18.46	6.19	5.18	28.37	79
		3	•	18.46	5.55	4.57	25.90	70
CRI 1s-13	1	1	•	19.17	7.19	5.73	30.36	96
		3	•	19.17	5.55	4.57	26.61	71
CRI 1s-15	1	1	•	20.59	7.19	5.73	31.78	97
		3	•	20.59	5.55	4.57	28.03	73
CRI 1s-17	1 1/2	1	•	22.01	7.19	5.73	33.69	102
		3	•	22.01	5.55	4.57	30.63	79
CRI 1s-19	1 1/2	1	-	23.43	7.19	5.73	35.11	104
		3	-	23.43	5.55	4.57	32.05	81
CRI 1s-21	1 1/2	1	-	24.84	7.19	5.73	36.52	106
		3	-	24.84	5.55	4.57	33.46	82
CRI 1s-23	1 1/2	1	-	26.26	7.19	5.73	37.94	107
		3	-	26.26	5.55	4.57	34.88	84
CRI 1s-25	2	1	-	27.68	7.19	5.73	40.24	120
		3	-	27.68	7.01	4.33	38.90	111
CRI 1s-27	2	1	-	29.09	7.19	5.73	41.65	122
		3	-	29.09	7.01	4.33	40.31	113

All dimensions in inches unless otherwise noted.

\*Oval flanged pump B1 and B1+B2 dimension is one inch less than ANSI flanged pump and weight is approximately 9 lbs. less.

• Available.

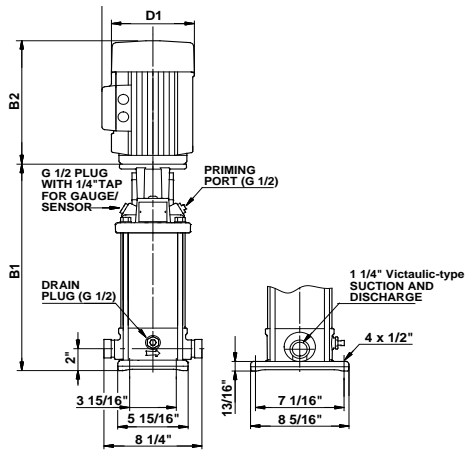

TM03 1454 2205

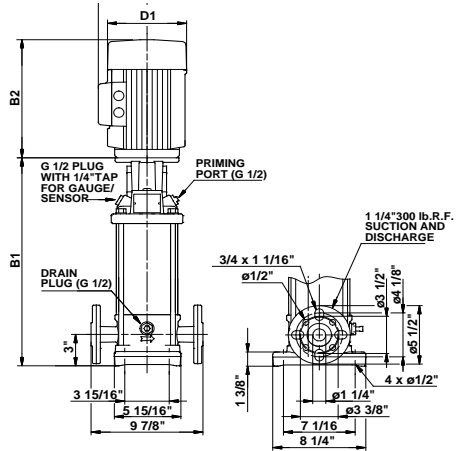

TM03 1453 2205

Pump type	P2 [hp]	Ph.	PJE*	ANSI dimensions [inch]				Ship Wt. [lbs.]
				B1	TEFC			
					D1	D2	B1+B2	
CRN 1s-2	1/3	1	•	12.09	6.19	5.18	21.38	63
		3	•	12.09	5.55	4.57	19.53	61
CRN 1s-3	1/3	1	•	12.09	6.19	5.18	21.38	64
		3	•	12.09	5.55	4.57	19.53	62
CRN 1s-4	1/3	1	•	12.80	6.19	5.18	22.09	65
		3	•	12.80	5.55	4.57	20.24	63
CRN 1s-5	1/3	1	•	13.50	6.19	5.18	22.79	66
		3	•	13.50	5.55	4.57	20.94	64
CRN 1s-6	1/2	1	•	14.21	6.19	5.18	23.50	70
		3	•	14.21	5.55	4.57	21.65	65
CRN 1s-7	1/2	1	•	14.92	6.19	5.18	24.21	71
		3	•	14.92	5.55	4.57	22.36	65
CRN 1s-8	1/2	1	•	15.63	6.19	5.18	24.92	72
		3	•	15.63	5.55	4.57	23.07	66
CRN 1s-9	3/4	1	•	16.34	6.19	5.18	26.25	77
		3	•	16.34	5.55	4.57	23.78	68
CRN 1s-10	3/4	1	•	17.05	6.19	5.18	26.96	78
		3	•	17.05	5.55	4.57	24.49	69
CRN 1s-11	3/4	1	•	17.76	6.19	5.18	27.67	78
		3	•	17.76	5.55	4.57	25.20	69
CRN 1s-12	3/4	1	•	18.46	6.19	5.18	28.37	79
		3	•	18.46	5.55	4.57	25.90	70
CRN 1s-13	1	1	•	19.17	7.19	5.73	30.36	96
		3	•	19.17	5.55	4.57	26.61	71
CRN 1s-15	1	1	•	20.59	7.19	5.73	31.78	97
		3	•	20.59	5.55	4.57	28.03	73
CRN 1s-17	1 1/2	1	•	22.01	7.19	5.73	33.69	102
		3	•	22.01	5.55	4.57	30.63	79
CRN 1s-19	1 1/2	1	•	23.43	7.19	5.73	35.11	104
		3	•	23.43	5.55	4.57	32.05	81
CRN 1s-21	1 1/2	1	•	24.84	7.19	5.73	36.52	105
		3	•	24.84	5.55	4.57	33.46	82
CRN 1s-23	1 1/2	1	•	26.26	7.19	5.73	37.94	107
		3	•	26.26	5.55	4.57	34.88	84
CRN 1s-25	2	1	•	27.68	7.19	5.73	40.24	120
		3	•	27.68	7.01	4.33	38.90	111
CRN 1s-27	2	1	•	29.09	7.19	5.73	41.65	122
		3	•	29.09	7.01	4.33	40.31	112

All dimensions in inches unless otherwise noted.

\*PJE flanged pump B1 and B1+B2 dimension is one inch less than ANSI flanged pump and weight is approximately 9 lbs. less.

• Available.